

DETAILS

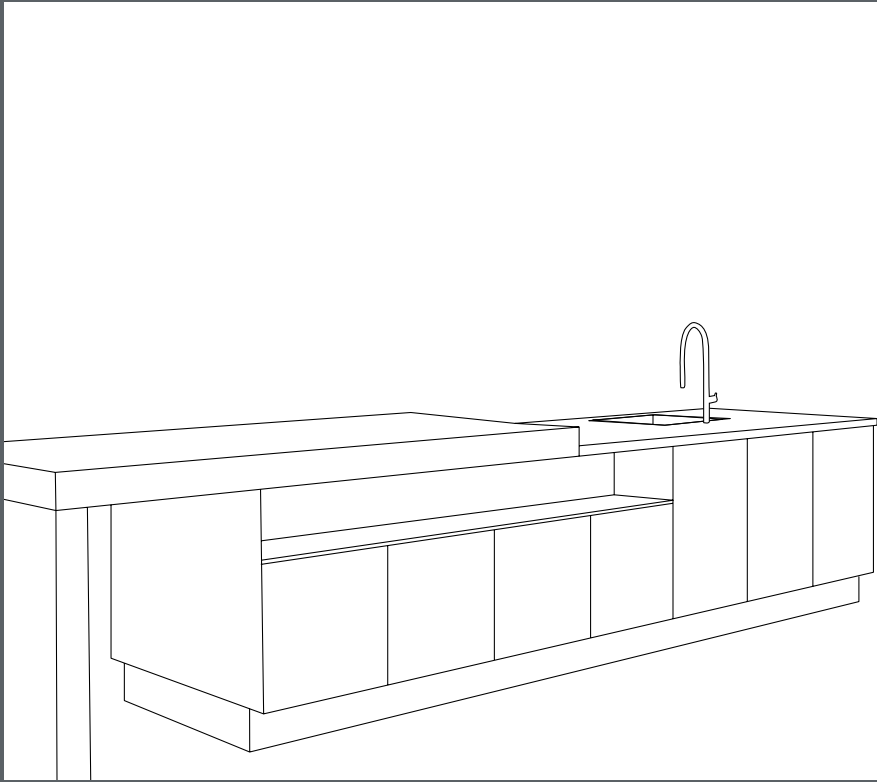

	CABINET PHILOSOPHY Filosofía del cuerpo Filosofia del corpo Philosophie du corps de cuisine	4	
	PULL-OUTS BASE UNITS Gavetas Armarios bajos Estraiibili Basi Coulissants Eléments bas	12	
	INTERIOR ORGANISATION SYSTEM Organización interior Sistema di organizzazione interno Système d'organisation intérieure	18	
	TALL UNITS Armarios columnas Colonne Armoires	34	
	EXTRAS Extras Optional Options	40	
	LIGHTING ELECTRONICS Iluminación Electrónica Illuminazione Elettronica Éclairage Électronique	44	
	FRONT OVERVIEW Frentes – Visión de conjunto Elenco modelli Aperçu des façades	52	
	WORKTOPS Encimeras Piani di lavoro Plans de travail	60	
	HANDLES Tiradores Maniglie Poignées	68	
	MATERIAL SCIENCE Ciencia de materiales Informazioni sul materiale Etude des matériaux	74	
	SUSTAINABILITY Sostenibilidad Sostenibilità Durabilité	80	

Cabinet Philosophy

Filosofía del cuerpo

Filosofia del corpo

Philosophie du corps de cuisine

GB The interior décor of our 13 cabinets is natural white. For the design cabinet colours lava grey and champagne however, the interior and exterior are available to match with the same colour interior décor. Furthermore, the cabinet exterior can also be painted in matt paint, veneer or high gloss paint instead of the standard panel décor.

ES La decoración interna de nuestros 13 cuerpos es blanco natural. No obstante, para los colores del cuerpo diseño: lava gris y champán, el interior está disponible igual que el exterior, con la decoración interna del mismo color. Además, en vez de pintar los laterales del cuerpo estándar, pueden pintarse los laterales externos del cuerpo. Y con pintura mate, efecto chapeado o pintura de alto brillo.

IT L'arredamento interno di 13 dei nostri corpi è bianco naturale. Per il corpo design sono disponibili i colori grigio lava e champagne sia per l'interno che per l'esterno e con decorazione interna dello stesso colore. Inoltre, al posto dei lati standard del corpo, è possibile verniciare i lati esterni, con vernice opaca, impiallacciatura e vernice brillante.

FR Treize de nos corps de cuisine standard ont un décor intérieur blanc naturel. Pour les corps de cuisine standard, dans les coloris gris lave et champagne, l'intérieur du corps est proposé dans la même couleur que l'extérieur – avec le même coloris de décor intérieur. Il est également possible de choisir des corps de cuisine aux faces externes laquées à la place de corps aux côtés standard. Ces finitions sont proposées en laque mat, en vernis de placage ou en en laque lustre.

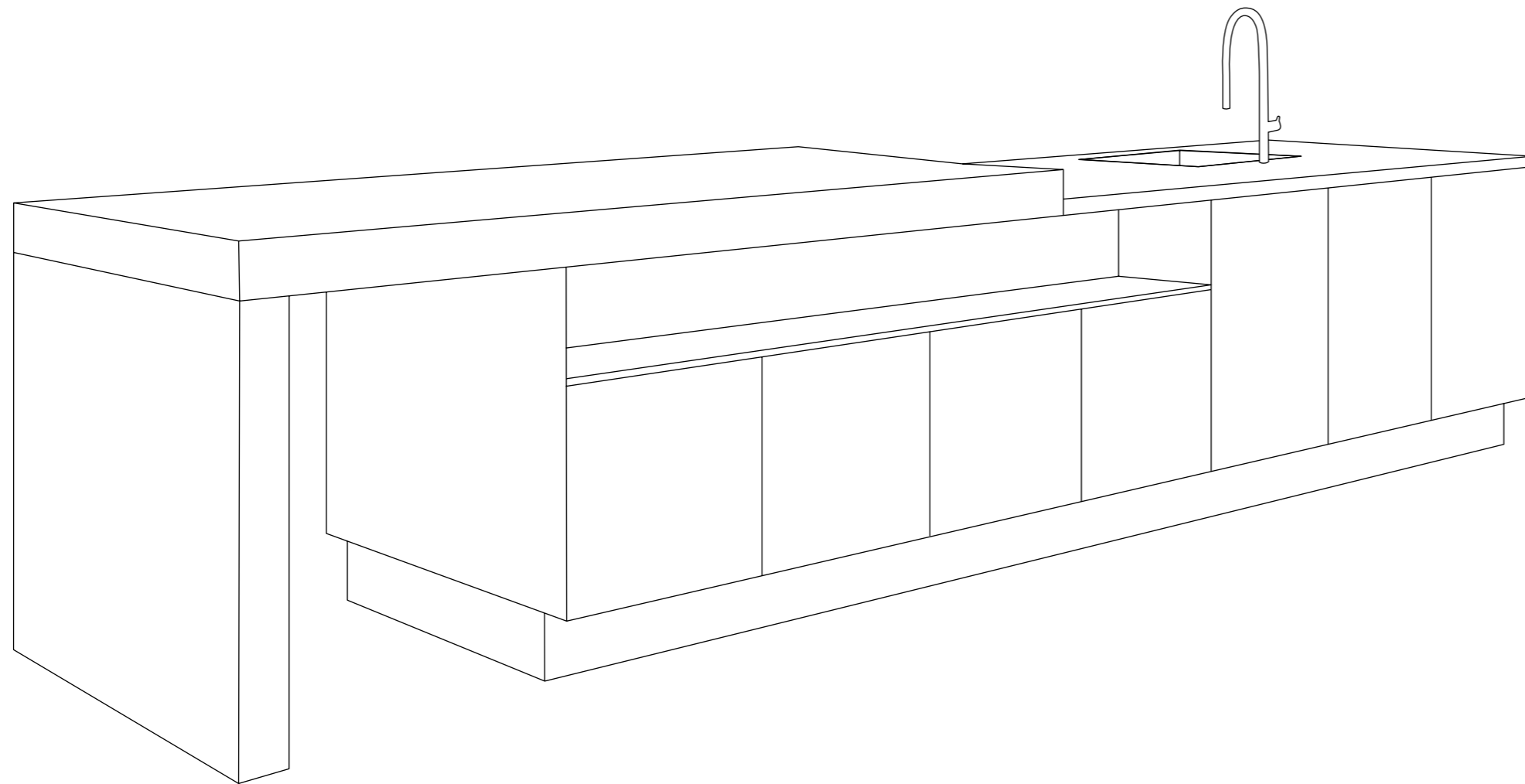

Carcase outside = see overview, Carcase inside = natural white, Carcase edge = same as
 Armazón exterior = véase esquema, Armazón interior = blanco natural, Canto del armazó = mismo color
 Corpo all'esterno = vedi panoramica, Corpo all'interno = bianco natura, Cordo corpo = stesso colore
 Extérieur du corps = voir l'aperçu, Intérieur du corps = blanc naturel, Chant du corps = couleurs identiques



3038 White Blanco Bianco Blanc	3302 Shiny white Blanco brillante Bianco lucido Blanc brillant	3025 Magnolia Magnolia Magnolia Magnolia
3211 Shiny magnolia Magnolia brillante Magnolia lucido Magnolia brillant	3052 Polar white Blanco polar Bianco polare Blanc polaire	3340 Cashmere Cachemir Cachemire Cachemire
3345 Shiny cashmere Cachemir brillante Cachemire lucido Cachemire brillant	3024 Stainless steel col. Color acero inox. Colore acciaio inox. Coloris acier inox.	3017 Basalt grey Gris basalto Grigio basalto Gris basalte
3088 Cornwall oak Roble cornwall Quercia cornwall Chêne cornwall	3104 Natural oak rough-cut finish Roble natural aserrado carrasposo Quercia natura ruvida Chêne naturel rugueux	3248 Light acacia Acacia luminoso Acacia chiara Acacia clair
3244 Grey acacia Acacia gris Acacia grigio Acacia gris		

Design carcase 2056 champagne, KA/KI/KK = champagne
 Armazón diseño 2056 champán, KA/KI/KK = champán
 Corpo design 2056 champagne, KA/KI/KK = champagne
 Corps design 2056 champagne, KA/KI/KK = champagne



Design carcase 2059 lava grey, KA/KI/KK = lava grey
 Armazón diseño 2059 lava gris, KA/KI/KK = lava gris
 Corpo design 2059 grigio lava, KA/KI/KK = grigio lava
 Corps design 2059 gris lave, KA/KI/KK = gris lave



GB Our cabinets do not just make an impression with their high quality look. They are especially easy to maintain and thus offer the best protection for the cabinets. Furthermore, they stand out with their colour consistency between the lower section of the cupboard and the upper cabinets; and with a material thickness of 16 mm for the panels and 19 mm for the base, they offer perfection in every detail.

ES Nuestros cuerpos no solo brillan por un aspecto de alta calidad, sino que además es muy fácil cuidarlos, por lo que ofrecen la mejor protección del cuerpo. Aparte de eso, el área del fondo del armario convence por la igualdad de color en los armarios colgantes. Y con un espesor del material de 16 mm para los laterales y de 19 mm para la base, demuestran la perfección hasta el mínimo detalle.

IT Non solo i nostri corpi brillano per il loro aspetto prezioso ma sono anche di facile manutenzione, il che agevola la migliore protezione del corpo stesso. Sul fondo attraggono per l'omogeneità cromatica dei pensili. Con un materiale di 16 mm di spessore sui lati e 19 mm sul fondo, questi mobili si presentano perfetti fin nel dettaglio.

FR Nos corps de cuisine ne brillent pas uniquement par l'excellence de leur esthétique, ils sont également faciles d'entretien et sont ainsi parfaitement protégés. Au niveau de la sous-face du meuble, ils séduisent en outre par l'uniformité des couleurs par rapport aux meubles du haut. Dotés d'une épaisseur de 16 mm pour les faces latérales et de 19 mm pour la partie basse, ils témoignent d'une perfection jusque dans le détail.

Dust seal
Perfil SAVE
Profilo Safe
Safe-Profil

Back panel with acrylate
Traseras
Pareti posteriori
Parois arrière avec de l'acrylique



GB Instead of a door shock absorber at the front, the cabinet front edges are fitted with a champagne coloured safe-profile. Therefore the cabinet offers optimum noise absorption. The safe-profile is permanently flexible and fully set and glued into the edge of the cabinet.

ES En vez de un retenedor en la parte delantera, las esquinas delanteras del cuerpo están equipadas con un perfil de protección de color champán. Por este motivo, el cuerpo proporciona una óptima amortiguación del ruido. El perfil de protección es siempre elástico y está enmarcado y encolado fijamente en la esquina del cuerpo.

IT Al posto di un ferma porta sul pannello frontale, i bordi anteriori del corpo sono dotati di un profilo di sicurezza color champagne. Così il corpo consente di attenuare in modo ottimale i rumori. Il profilo di sicurezza è elastico e viene scanalato e incollato saldamente su tutta la circonferenza del bordo del corpo.

FR À la place d'un amortisseur de porte à hauteur de la façade, les chants du corps de cuisine sont équipés d'un profil de sécurité de couleur champagne. Ainsi, le corps offre une parfaite atténuation du bruit. Le profil de sécurité garde toute son élasticité ; il est fixé tout autour du chant du caisson puis collé.

GB The coated 3 mm solid fibre back panel is screwed into the cabinet and is additionally sealed at the sides with acrylate for optimum noise absorption.

ES El panel trasero revestido de fibra dura de 3 mm se atornilla al cuerpo y adicionalmente se insonoriza lateralmente con acrilato para un aislamiento acústico estupendo.

IT Il pannello posteriore a fibra dura rivestito viene collegato a vite per 3 mm con il corpo e poi sigillato sui lati con dell'acrilato, che garantisce un ottimale isolamento acustico.

FR Le panneau arrière en fibres dures, d'une épaisseur de 3 mm et recouvert d'un placage, est fixé au caisson avec des vis et fermé hermétiquement de côté avec de l'acrylate, pour un amortissement optimal du bruit.

35 cm carcass depth
Profundidad del armazón 35 cm
Profondità del corpo 35 cm
Profondeur du corps 35 cm



GB Extra deep upper cabinets also offer space for large bowls and pizza plates (interior depth 33 cm).

ES Los armarios colgantes de gran profundidad también ofrecen espacio para grandes fuentes y platos de pizza (profundidad interior 33 cm).

IT I pensili molto profondi offrono spazio per grandi insalatiere e piatti da pizza (profondità interna di 33 cm).

FR Des meubles hauts particulièrement profonds offrent également de la place pour de grands saladiers et des assiettes à pizza (profondeur 33 cm).

Bottom shelf 19 mm thick
Fondo 19 mm de grosor
Sottopiano 19 mm di spessore
Paroi inférieure 19 mm d'épaisseur



GB The inset shelves and also the bottom panels are 19 mm thick and withstand high loads.

ES No solo las baldas tienen un espesor de 19 mm, también los fondos de armario están provistos de eso, por lo que soportan cargas muy elevadas.

IT Non solo i ripiani ma anche il fondo presenta uno spessore di 19 mm, in grado pertanto di sopportare carichi elevati.

FR Les tablettes ainsi que les panneaux inférieurs ont une épaisseur de 19 mm et garantissent une haute stabilité.

Metal shelf support with safety pin
Soporte de estantes metálico con seguro de extracción
Supporto del fondo metallico con dispositivo di sicurezza Taquets d'étagère en métal avec arrêt



Covering wall unit suspension
Colgador de muebles altos
Fissaggio dei pensili coperto
Suspension des éléments muraux



GB The shelves are particularly hard-wearing and can be adjusted individually via a row of holes in the body.

IT I ripiani sono molto resistenti e possono essere regolati individualmente nel corpo grazie ad una serie di fori.

GB The cupboard bracket is located out of sight behind back wall of the hanging cupboard and can be adjusted in three dimensions. Covering caps inside the cupboard cover the adjustment screws.

IT La sospensione è invisibile dietro la parete posteriore del pensile alto ed è regolabile in tre dimensioni. I cappucci di copertura coprono le viti di regolazione all'interno del pensile.

ES Los suelos son sumamente resistentes y, gracias a una hilera de orificios en el armazón, pueden ajustarse individualmente.

FR Les étagères sont très résistantes et réglables en hauteur grâce à la rangée de trous dans le caisson du meuble.

ES Los dispositivos de suspensión de los armarios se encuentran escondidos tras la pared posterior del armario alto y se pueden ajustar en tres dimensiones. Las tapas de cubierta en el interior del armario ocultan los tornillos de ajuste.

FR Le meuble est équipé de suspensions invisibles sur la partie supérieure de la paroi arrière. Il est ajustable et réglable en hauteur, en profondeur et en largeur. Des cache-vis recouvrent les vis de réglage à l'intérieur des meubles.

Hinge with integrated damping
Bisagra con amortiguación integrada
Cerniera con ammortizzazione integrato
Charnière avec amortisseur intégré

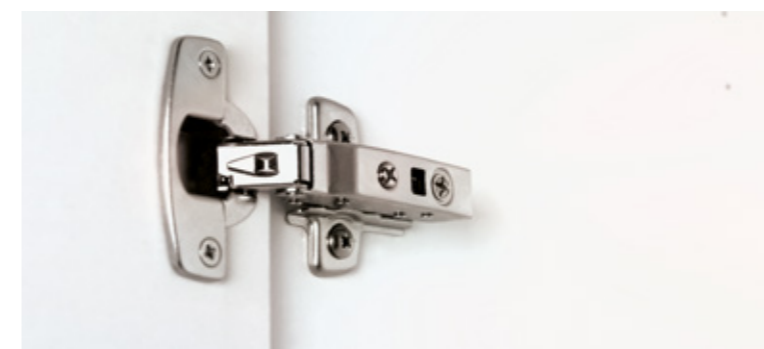

GB Installation and disassembling is quick and easy and requires no tools. The hinge can be adjusted in three dimensions.

ES Los muebles se pueden montar y desmontar de forma rápida y sencilla sin herramientas. La bisagra se puede ajustar en tres dimensiones.

IT Montaggio e smontaggio non richiedono un grande dispendio di tempo e non necessitano l'uso di attrezzi. La cerniera è regolabile in tre dimensioni.

FR Le montage ou le démontage sont rapides et simples, sans outils. La charnière peut être réglée en hauteur, en profondeur et en largeur.

Profiled railing
Encolada sobre el perfil de regleta
Gola incollata al corpo
Profil encollé au niveau de l'étagère inférieure



GB At product range ARThandleless, the bottom shelf has a cross-bonded moulding for opening the hanging cupboard.

ES Para abrir los armarios altos de la serie sin tiradores (ART), el fondo del armario cuenta con un listón de perfil encolado.

IT Per aprire i pensili alti senza maniglia (ART), il ripiano inferiore viene rinforzato con listello profilato incollato.

FR Pour ouvrir l'élément haut équipé du système ARTsans poignée, un profil est collé sur l'étagère inférieure.

Pull-outs | Base units

Gavetas | Armarios bajos
Estraibili | Basi
Coulissants | Eléments bas

GB The pull-outs are available in two colours and can be designed in the same colours as the standard cabinet colours; lava grey and champagne. The metal frame is fitted with an elegant and strong (edge radius 1 mm) powder coated, metal back panel. The easy wipe inner moulding makes the pull-outs very easy to clean. The synchronising mechanism guarantees high performance running and side stability. The eccentric height adjustment allows the pull-outs to be adjusted 3 dimensionally. The fully extractable lead rails with an automatic retraction mechanism are fitted with soft retraction as standard.

ES Los cajones están disponibles en dos colores y pueden planificarse con los mismos colores del cuerpo estándar: lava gris y champán. El cerco de metal está equipado con un bello y robusto panel posterior de metal revestido en polvo (radio de la esquina 1 mm). Gracias a un canto interior redondeado para facilitar la limpieza, es muy sencillo cuidar los cajones. La sincronización garantiza una elevada suavidad de marcha y una estabilidad lateral. Debido al ajuste de altura excéntrico, los cajones se pueden ajustar tridimensionalmente. Los rieles-guía para la extensión total con autocierre están equipados de serie con un mecanismo de cierre suave.

IT I sistemi ad estrazione sono disponibili in due tonalità, ordinabili negli stessi colori standard del corpo: grigio lava e champagne. La struttura in metallo include un pannello posteriore in metallo, elegante, stabile (raggio del bordo di 1 mm) e verniciato a polveri. Grazie alla scanalatura interna, i sistemi ad estrazione sono facili da pulire. La sincronizzazione garantisce alte prestazioni e la stabilità laterale. Grazie alla regolazione dell'altezza a eccentrico, i sistemi ad estrazione possono essere regolati in 3 dimensioni. Le guide a estrazione completa con chiusura automatica sono dotati di un sistema ammortizzante.

FR Les coulissants sont proposés en deux couleurs et peuvent être harmonisés avec les couleurs du corps de cuisine standard, gris lave et champagne. L'ébrasement métallique (épaisseur de 1 mm) est équipé d'une belle et solide paroi arrière métallique au revêtement pulvérisé. Les coulissants sont très faciles d'entretien grâce à la gorge de nettoyage placée dans l'agencement intérieur. La synchronisation assure une grande longévité et une stabilité latérale. Grâce au réglage en hauteur excentrique, les coulissants sont ajustables en 3 dimensions. Les rails de guidage, à sortie totale et dotés d'un amortisseur automatique, sont équipés en série d'une fermeture assistée pour une ouverture et une fermeture tout en douceur.

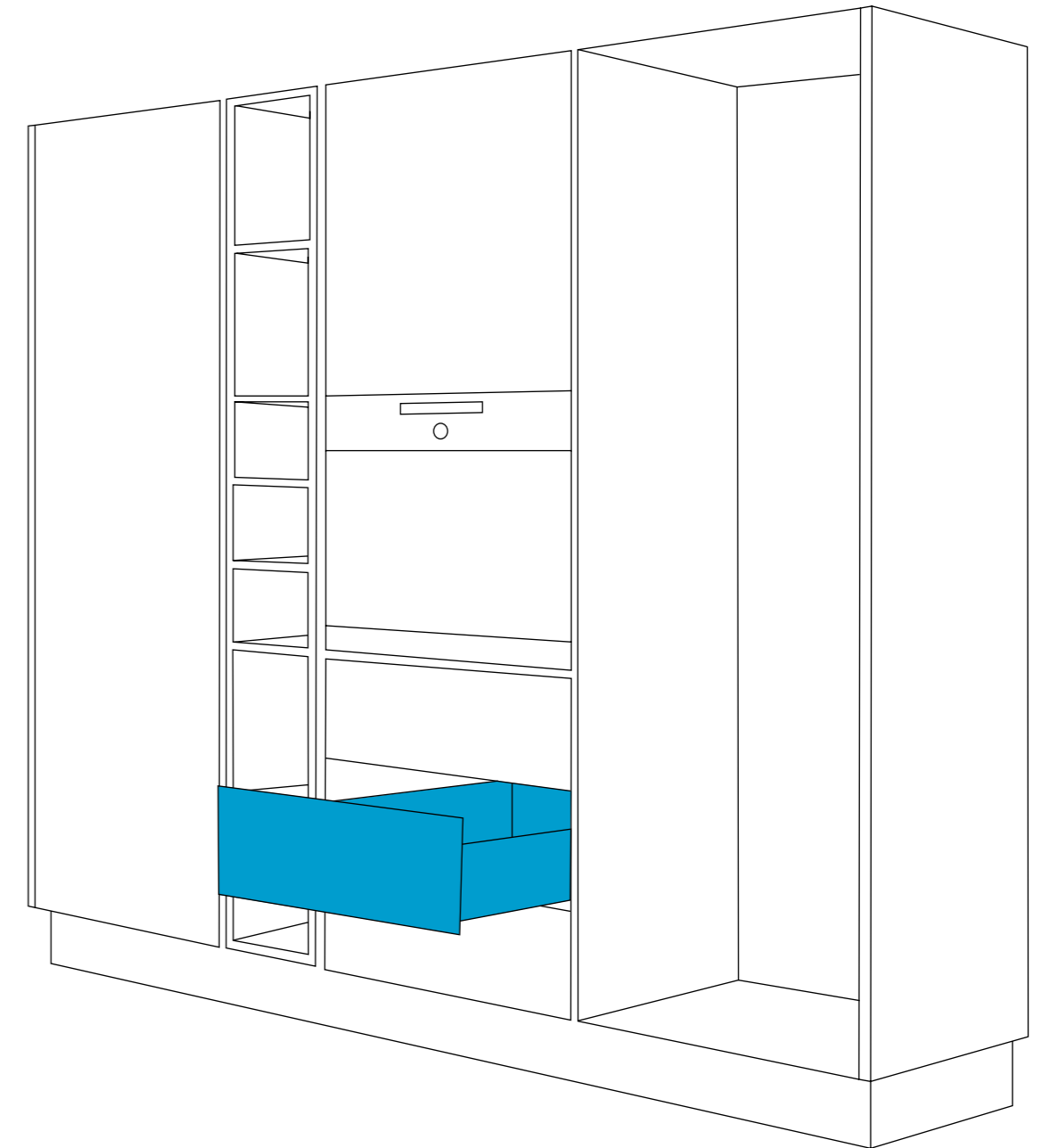
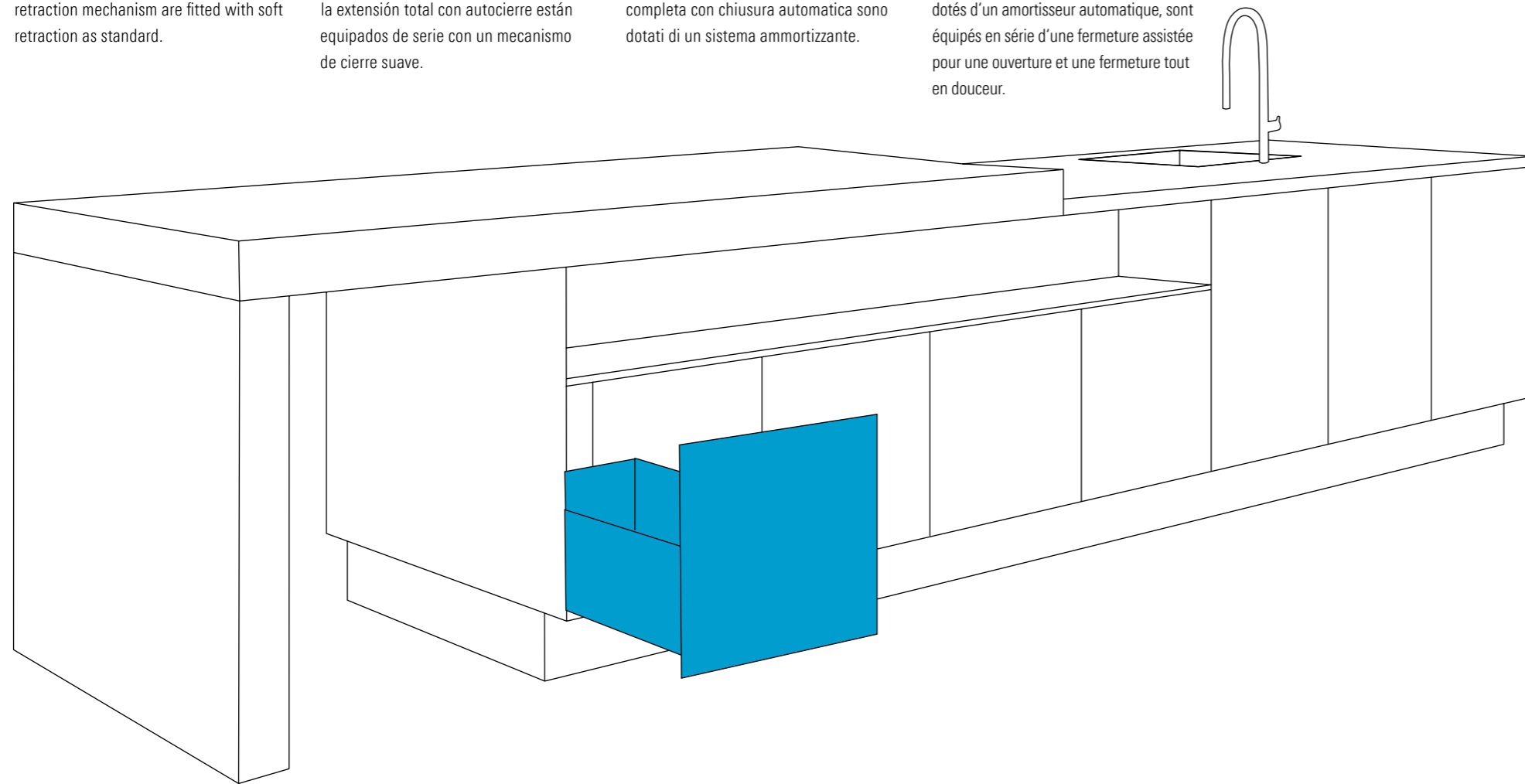

Metro Line R

Metro Box R

Metro Glas R

Metro Glas R LED

Champagne
Champán
Champagne
Champagne



51



52



53



54

Lava grey
Lava gris
Grigio lava
Gris lave



61



62



63



64

GB Standard finish

ES Acabado estándar

IT Esecuzione standard

FR Esecuzione standard

GB The sides are closed.

ES Los lados están cerrados.

IT I pareti laterali sono chiuse.

FR Les côtés latéraux sont fermés.

GB Instead of the railing glass sides are provided.

ES En lugar de una barandilla montaremos cristal en los laterales de las gavetas.

IT La parete posteriore viene fornita in vetro e non in metallo.

FR A la place de la barre, le châssis sera équipé latéralement de paroi en verre.

GB The glass for the glass sides are provided additionally with LED-lighting.

ES Ambos lados serán suministrados con la iluminación LED.

IT I pannelli di vetro delle sponde laterali estraibile saranno forniti con illuminazione.

FR Les côtés vitrés du caisson sont équipés d'éclairage DEL en plus.

Base unit with interior drawer with metal panel
 Armario bajo con cajón interior con frente de metal
 Base con cassetto interno con fascia in metallo
 Élément bas avec tiroir intérieur avec face en métal

Interior drawer with glass panel
 Cajón interior con frente de cristal
 Cassetto interno con fascia in vetro
 Tiroir intérieur avec face en verre



GB The inner pull-out can be supplied with a glass front for a small additional charge.

ES Por una pequeña tasa adicional, el cajón interior puede suministrarse con embellecedor de vidrio.

IT Con un supplemento minimo, il cassetto interno può essere dotato di pannello in vetro.

FR Moyennant une faible majoration du prix, le tiroir à l'anglaise peut être livré avec une face en verre.

Base unit with interior drawer and carrier
 Armario bajo con cajón interior y pitón de arrastre
 Base con cassetto interno e briglia
 Élément bas avec tiroir intérieur et fixation



GB The carrier can be integrated into the recessed grip of the metal panel.

ES El tope de arrastre puede integrarse en el tirador o el embellecedor de metal.

IT Il sistema di trasporto può essere integrato nella maniglia incassata del pannello metallico.

FR L'élément d'entraînement peut être intégré dans la moulure de poignée du cache en métal.

Interior organisation system

Organización interior
Sistema di organizzazione interno
Système d'organisation intérieure

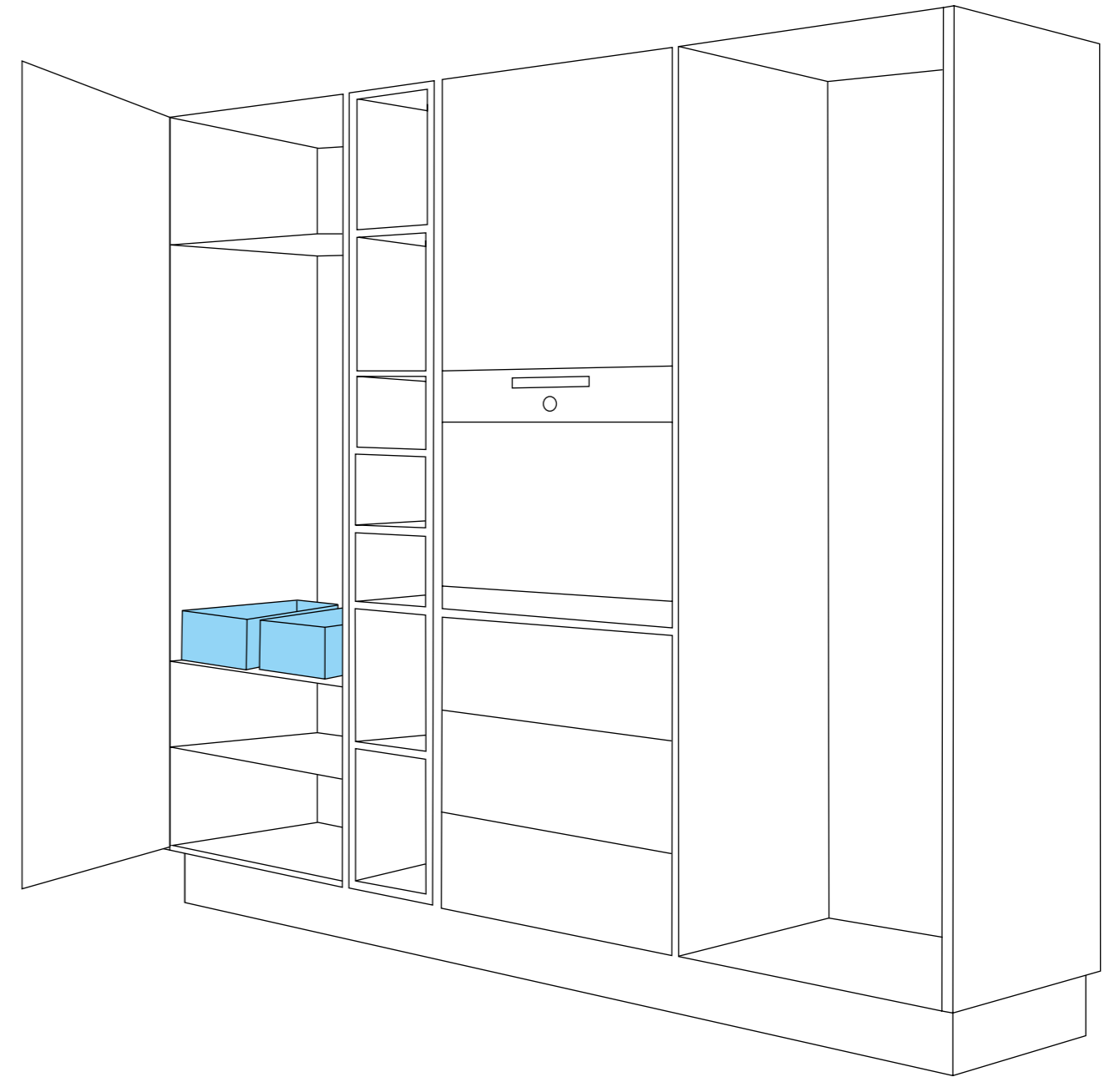
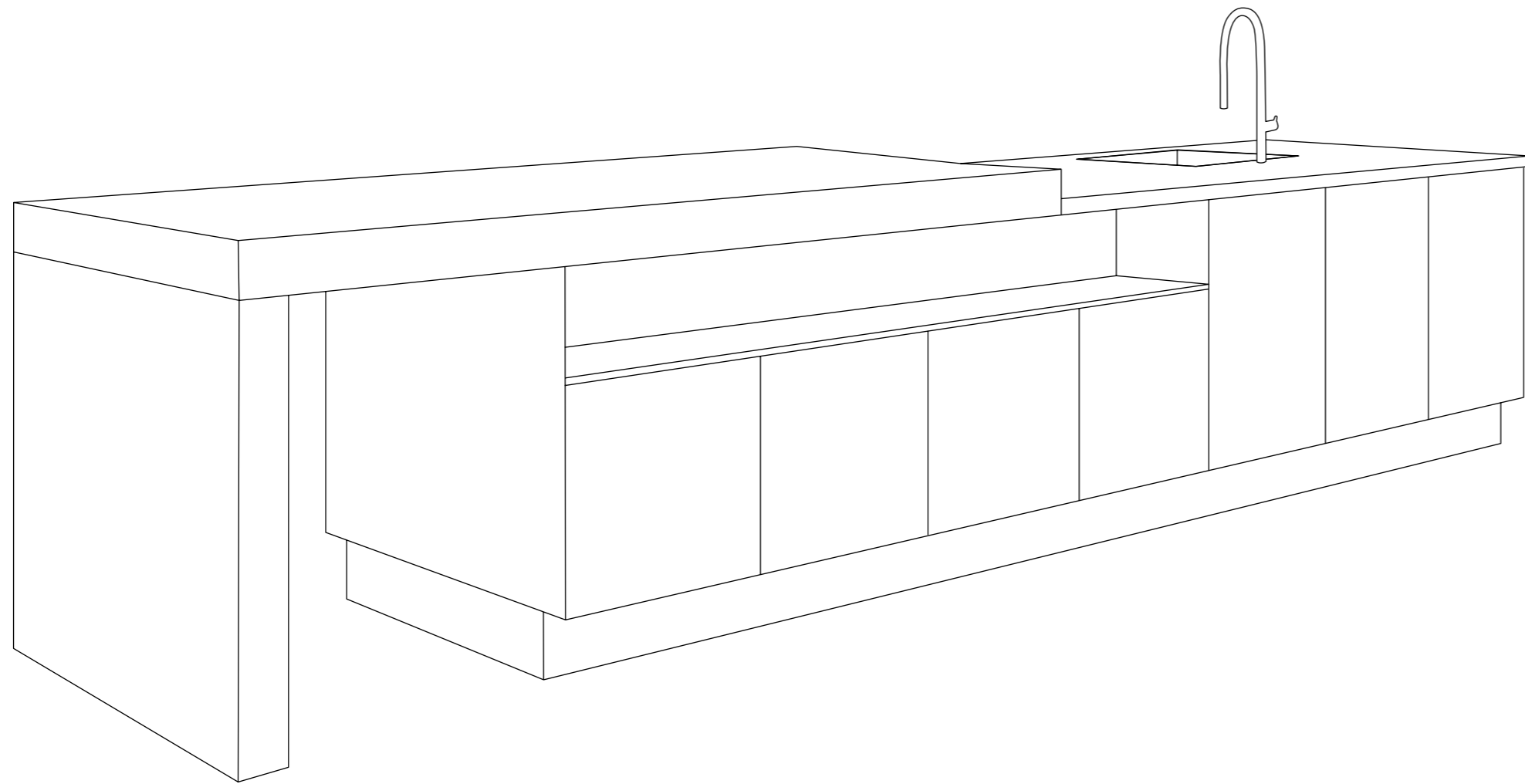

Laminate
Material sintético
Laminato
Mélaminé



GB Wether base units with solid wood inside organisation system and cutlery trays or integrated, additional drawers – innovative storage space concepts simplify your work and alleviate organisation.

ES Ya sean las gavetas de madera maciza con organización interior, o los portacubiertos, o los cajones adicionales integrados. Los innovadores conceptos de espacio de almacenaje facilitan el trabajo y consiguen el orden.

IT Che si tratti di cassetti ad estrazione totale in legno massello con inserti per le posate, o di cassetti integrati supplementari, l'organizzazione degli spazi semplifica la vita e crea ordine.

FR Qu'il s'agisse de coulissant avec organisation intérieure en bois massif et de ramasse-couverts ou de tiroirs intégrés – les concepts innovants de rangement facilitent le travail et mettent de l'ordre.

Solid wood
Madera maciza
Legno massiccio
Bois massif



Interior organisation system MOVE
 Organización interior MOVE
 Sistema di organizzazione interno MOVE
 Système d'organisation intérieure MOVE



GB Whether fully extractable sections with inner fittings of heavy wood and cutlery trays or integrated additional pull-outs – innovative storage concepts make work easier and achieve tidiness quickly and simply.

ES Tanto los cajones de extensión total con organización interior de madera maciza y cuberteros como los cajones adicionalmente integrados son conceptos de almacenaje innovadores que facilitan el trabajo y logran el orden rápida y sencillamente.

IT Sia con sistemi ad estrazione completa con interno in legno massello e inserti per le posate che con l'integrazione di cassetti aggiuntivi, gli innovativi concetti di spazio da dispensa facilitano il lavoro e consentono un'organizzazione facile e veloce.

FR Le système d'aménagement intérieur MOVE en bois massif offre une multitude de possibilités grâce aux éléments réglables, quatre compartiments en trois hauteurs et deux surfaces différentes. Range-couverts, dérouleur pour film étirable, porte-couteaux et éléments de compensation parachèvent le concept et un tapis antidérapant fait en sorte que tout reste à sa place.

Interior organisation system for pull-outs MOVE
 Organización interior para gavetas MOVE
 Sistema di organizzazione interno per estraibili MOVE
 Système d'organisation intérieure pour coulissants MOVE



Interior organisation system MOVE
 Organización interior MOVE
 Sistema di organizzazione interno MOVE
 Système d'organisation intérieure MOVE



Wall unit with interior organisation MOVE
 Armario alto con organización interior MOVE
 Pensile con sistema di organizzazione interno MOVE
 Element mural avec système d'organisation intérieure MOVE



GB Due to their construction, open boxes can also be integrated into the wall unit.

ES Debido a su diseño, las cajas abiertas pueden integrarse también en el armario alto.

IT Grazie al loro design, possono essere integrati nei pensili anche degli scomparti aperti.

FR Grâce à leur conception, les boîtes ouvertes peuvent également être intégrées dans le meuble mural.

Interior organisation system MOVE for tall unit for provisions
 Organización interior MOVE para armario de almacenaje
 Sistema di organizzazione interno MOVE per colonna dispensa
 Système d'organisation intérieure MOVE pour armoire à provisions



GB Open boxes can also section off the shelves of the high larder cabinets.

ES Con las cajas abiertas, los estantes de los armarios columnas para provisiones pueden dividirse adicionalmente.

IT Con gli scomparti aperti, le mensole dei mobili alti da dispensa possono essere ulteriormente suddivise.

FR Grâce aux boîtes ouvertes, les tablettes des meubles hauts dédiés au stockage peuvent être réparties autrement.

Interior organisation MOVE with recess equipment Linero MosaiQ
 Organización interior MOVE con equipamiento de entrepaño Linero MosaiQ
 Sistema di organizzazione interno MOVE con corredo per nicchie Linero MosaiQ
 Système d'organisation intérieure pour équipement de crédence Linero MosaiQ



GB The universal shelf of the corner construction unit can also be fitted with an open box.

ES El anaquel universal de la barra puede equiparse además con una caja abierta.

IT Anche il vassoio universale dell'asta per utensili può essere dotato di scomparti aperti.

FR Le support universel pour crédence de cuisine peut, en plus, accueillir une boîte ouverte.

Base unit with interior pull-outs with metal panel
Armario bajo con gavetas interiores con frente de metal
Base con estraibili interni con fascia in metallo
Élément bas avec coulissants intérieurs avec face en métal



Base unit with interior pull-outs and glass panel
Armario bajo con gavetas interiores con frente de cristal
Base con estraibili interni con fascia in vetro
Élément bas avec coulissants intérieurs et face en verre



GB With a metal panel as standard, the inner pull-out can be supplied with a glass panel for a small additional charge.

ES De serie con embellecedor de metal. Por una pequeña tasa adicional, el cajón interior puede suministrarse con embellecedor de vidrio.

IT Piastra metallica di serie. Con un supplemento minimo, nel sistema ad estrazione interno può essere integrato un pannello in vetro.

FR En série avec cache en métal. Moyennant une faible majoration du prix, le tiroir à l'anglaise peut être livré avec une face en verre.

Base unit for provision with clip-on shelves
Armario bajo para provisiones Bandejas colgables con estantes fijos
Base per dispensai Mensole da appendere con ripiano fisso
Élément bas pour provisions Etagère à suspendre avec un fond résistant



Base unit with bag for baguette
Armario bajo con bolsa para pan
Base con sacchetto per pane
Élément bas avec sac pour baguette





1



2



3



4



4+5



6



7



8

GB Waste system Separato with SafetyKit (only for Germany)

ES Sistema de basura Separato con SafetyKit (solo en Alemania)

IT Pattumiera Separato con SafetyKit (solo per la Germania)

FR Système de déchets Separato avec SafetyKit (uniquement pour Allemagne)

GB Waste system for pull-out

ES Sistema de basura para gaveta

IT Pattumiera per estraibile

FR Système de déchets pour les coulissants

GB Base unit with waste system. Pull-out frame with removable waste sorter.

ES Armario bajo con sistema de basuras. Estructura de extracción con cubos de basura colgados.

IT Base con pattumiera. Telaio estraibile con contenitori rifiuti da agganciare.

FR Élément bas avec système de déchets. Support coulissant avec poubelles encastrables.

GB Sink base unit with waste system

ES Armario bajo para freg. con sistema de basuras

IT Base per lavello con pattumiera

FR Élément sous-évier avec système de déchets

GB Sink base cabinet with waste disposal system; shortened pull-out frame with hanging waste container. This is necessary when built-in plumbing cannot be moved.

ES Armario debajo del fregadero con sistema para residuos. Bastidor extraíble reducido acortado con recipientes colgantes para residuos. Necesario si no se pueden cambiar de lugar las conexiones constructivas.

IT Mobile per lavello con sistema per i rifiuti. Telaio ad estrazione più corto, con incasso dei contenitori per i rifiuti. Necessario se le connessioni strutturali non possono essere spostate.

FR Meuble sous-évier équipé d'un système pour déchets. Cadre télescopique raccourci avec conteneur à déchets muni d'un dispositif de suspension. Nécessaire dans le cas où les raccords de construction ne peuvent pas être déplacés.

GB Sink base unit with waste system MüllEX

ES Armario bajo para freg. con sistema de basuras MüllEX

IT Base per lavello con pattumiera MüllEX

FR Élément sous-évier avec système de déchets MüllEX

GB Base unit for provisions and bottles with interior drawer and removable bottle-rack.

ES Armario bajo para provisiones y botellas con cajón interior y cesta extraíble para botellas.

IT Base per provviste e bottiglie con cassetto interno e portabottiglie amovibile.

FR Élément bas pour provisions et bouteilles avec tiroir intérieur et porte-bouteille amovible.

Base unit with cooking AGENT
 Armario bajo con cooking AGENT
 Base con cooking AGENT
 Élément bas avec cooking AGENT

Base unit with 71 cm carcass depth
 Armario bajo con profundidad del armazón 71 cm
 Base con profondità del corpo 71 cm
 Élément bas avec profondeur du corps 71 cm



GB Base unit with cooking AGENT and soft-closing system.

IT Base con cooking AGENT e chiusura soft.

GB Extra deep cabinets are available as a storage cupboard or as base cabinet for cooking panels.

IT Armadi da terra molto profondi, disponibili come mobili da dispensa o da piano cottura.

ES Armario bajo con cooking AGENT y cierre soft.

FR Élément bas avec cooking AGENT et fermeture amortie.

ES Hay disponibles armarios bajos muy profundos para las provisiones o armarios bajos debajo de las placas de cocción.

FR Éléments bas ultra profonds destinés à servir de garde-manger ou disponibles comme sous-élément de la plaque de cuisson.

Corner base unit LeMans with metal band
 Armario bajo de rincón LeMans con banda metálica
 Base angolare LeMans con fascia in metallo
 Élément bas d'angle LeMans av. bastingage plat en métal

Corner base unit with corner pull-out
 Armario bajo de rincón con gaveta giratorio
 Base angolare con estraibile ruotabile
 Élément bas d'angle avec set de plateaux pivotants



GB Heavy duty and totally robust: corner units with swing-out shelves make full use of every nook and cranny.

ES Sumamente resistentes y de gran solidez: Armarios de rincón con estantes giratorios garantizan espacio hasta en el último rincón.

IT Grande portata unita a grande solidità: le basi angolari con piani girevoli estraibili sfruttano lo spazio anche nell'angolo più remoto.

FR Excellente résistance et solidité: Les éléments d'angle à plateaux pivotants offrent de l'espace de rangement jusque dans les moindres recoins.

Tall units

Armarios columnas
Colonne
Armoires

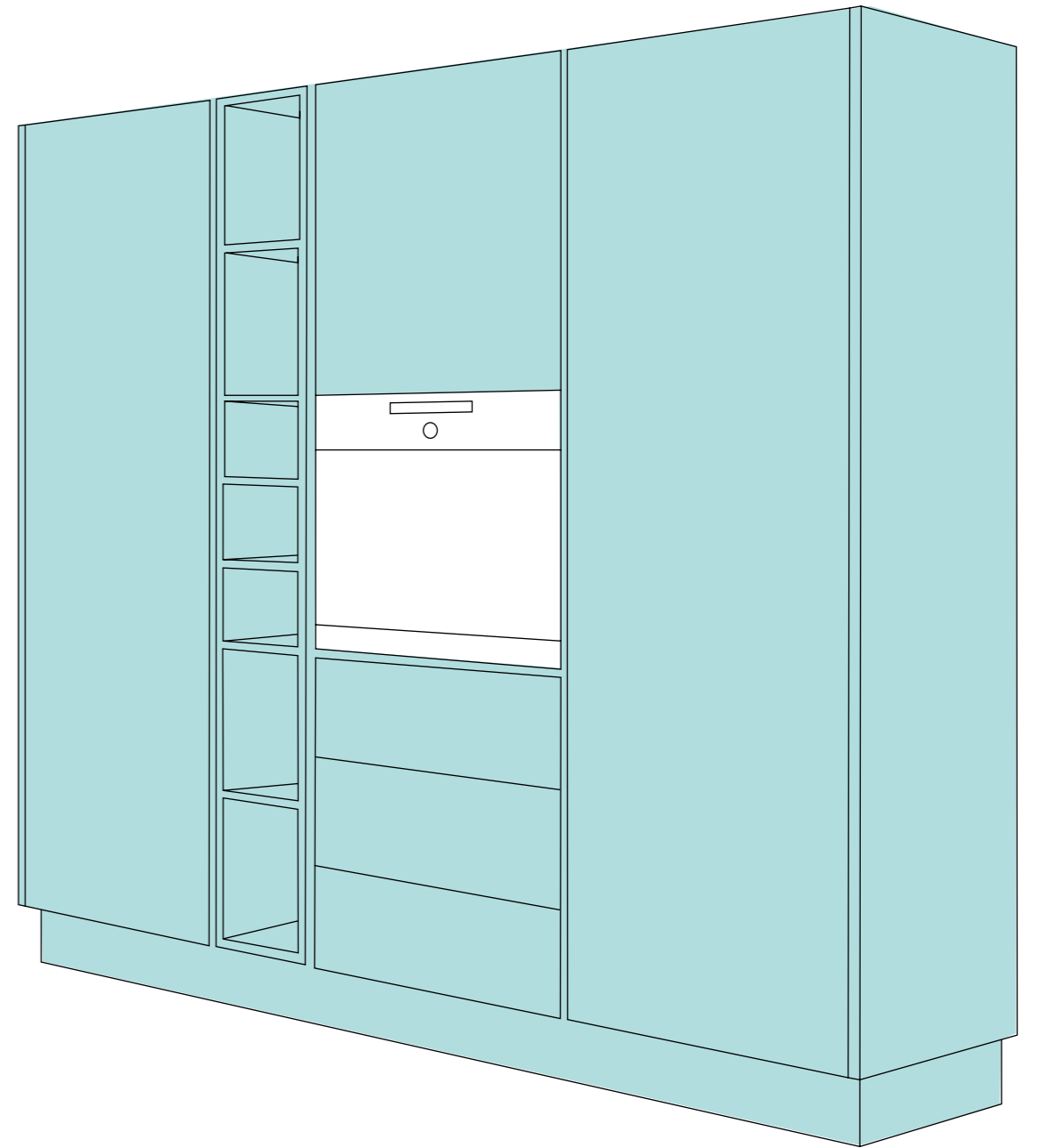
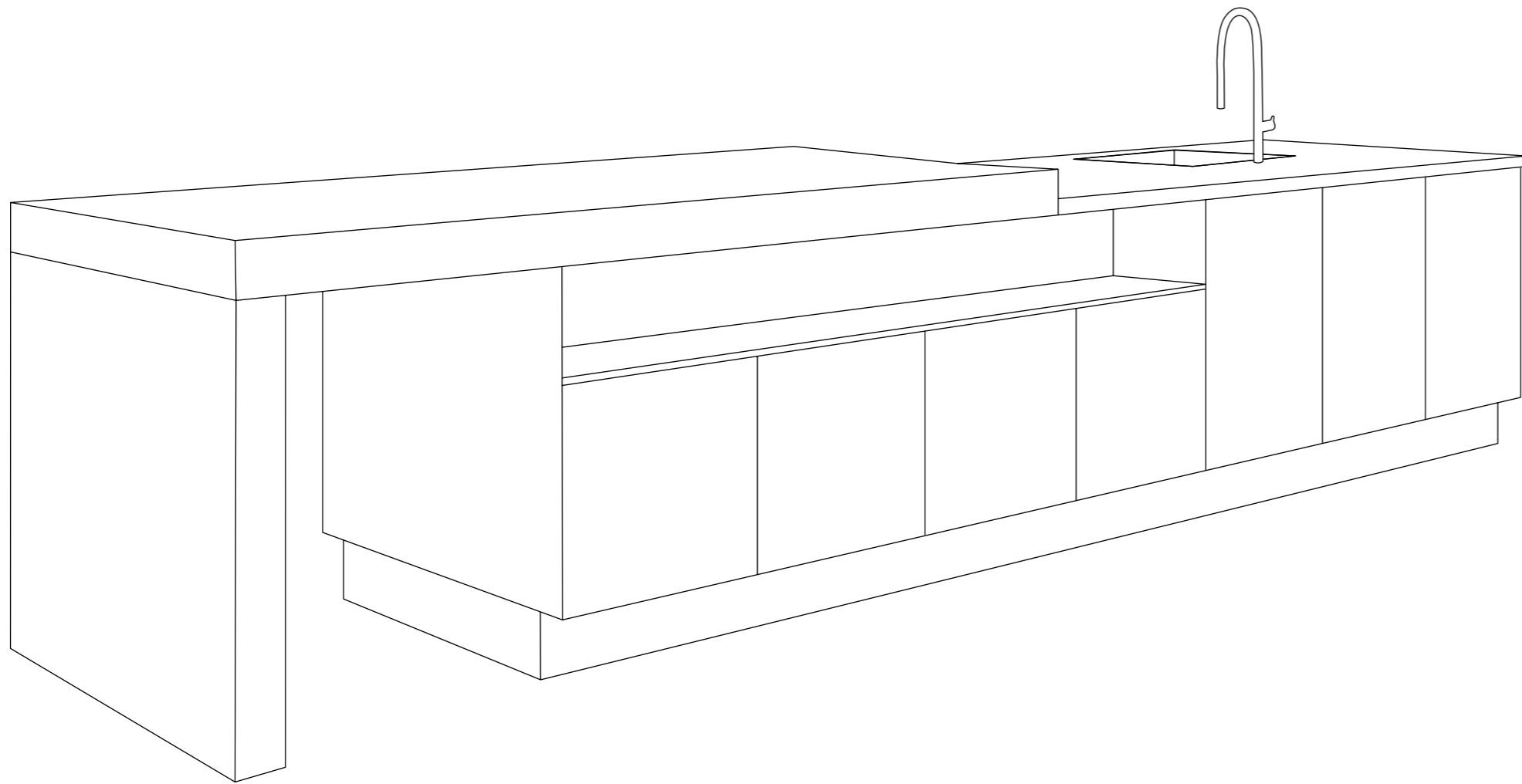

Tall unit for provisions with clip-on shelves
 Armario de almacenaje con bandejas colgables
 Colonna dispensa con mensole da appendere
 Armoire à provisions avec étagère à suspendre

Tall unit for provisions with GlasLine
 Armario de almacenaje con GlasLine
 Colonna dispensa con GlasLine
 Armoire à provisions avec GlasLine

Tall unit for provisions with tandem swivel pull-out
 Armario de almacenaje con gaveta giratoria tandem
 Colonna dispensa con estr. ribaltabile tandem
 Armoire à provisions avec coulissant pivotant tandem



GB Adjustable hanging shelves with solid bases and metal strips are available with GlasLine for a small additional charge. With glass trim to the side instead of the metal strip.

ES Los bandejas colgables regulables con fondo fijo y banda de metal también se pueden suministrar con banda de vidrio por una pequeña tasa adicional. Con cercos de vidrio laterales en vez de la banda de metal.

IT Mensole regolabili da appendere con fondo rigido e fascia di metallo, disponibili anche con linea di vetro con l'aggiunta di un supplemento minimo. Con telaio laterale in vetro al posto della fascia di metallo.

FR Tablettes réglables munies d'un dispositif de suspension, à base solide et dotées d'une bande métallique. Disponibles avec GlasLine moyennant une faible majoration du prix. Équipées d'une bande métallique à la place des ébrasements latéraux en verre.

GB Clip-on shelves with metal band.

ES Bandejas colgables regulables con fondo fijo.

IT Mensole da appendere con ripiano fisso con fascia in metallo.

FR Étagère à suspendre avec un fond résistant av. bastingage plat en métal.

Tall unit for appliances with integrated ventilation
Armario columna para electrodomésticos con ventilación integrada
Armadio a colonna con ventilazione integrata
Armoire à appareil avec une ventilation intégrée



GB The fitted back base and the offset construction base cover the necessary ventilation for the refrigeration unit behind the front.

ES Mediante una base retráctil y la base de construcción desplazada se proporciona la ventilación necesaria para el refrigerador detrás de la parte frontal.

IT Il fondo ad incasso e il piano di costruzione sfalsato nascondono la ventilazione necessaria del dispositivo di raffreddamento dietro al pannello frontale.

FR La ventilation nécessaire au réfrigérateur est dissimulée derrière la façade au moyen d'une tablette placée en retrait et du fond de construction décalé.

Tall unit for appliances with special sized lift-up door
Armario columna para electrodomésticos con puerta elevable variable
Colonna per elettrodomestici con anta basculante di compensazione
Armoire pour appareils avec porte lift de compensation



GB Electrical devices that cannot be integrated are hidden behind a furniture front with the lift door. Matching fronts allow the storage space above a device recess to be used in full and reduce horizontal joints.

ES Con la puerta elevable, los electrodomésticos que no se pueden integrar desaparecen detrás del frente del mueble. Los frentes de compensación permiten aprovechar el espacio sobre el hueco previsto para un electrodoméstico y se reducen las ranuras horizontales.

IT Con l'anta sollevabile, gli elettrodomestici non integrabili scompaiono dietro al pannello del mobile. I pannelli di compensazione rendono pienamente utilizzabile lo spazio disponibile sugli apparecchi e vengono ridotti i giunti orizzontali.

FR Grâce à la porte lift, les appareils électroménagers non encastrables disparaissent discrètement derrière une façade. Des façades de compensation permettent une utilisation optimale de l'espace situé au-dessus d'un emplacement pour appareils électroménagers et permettent de réduire les joints horizontaux.

Extras

Extras
Optional
Options

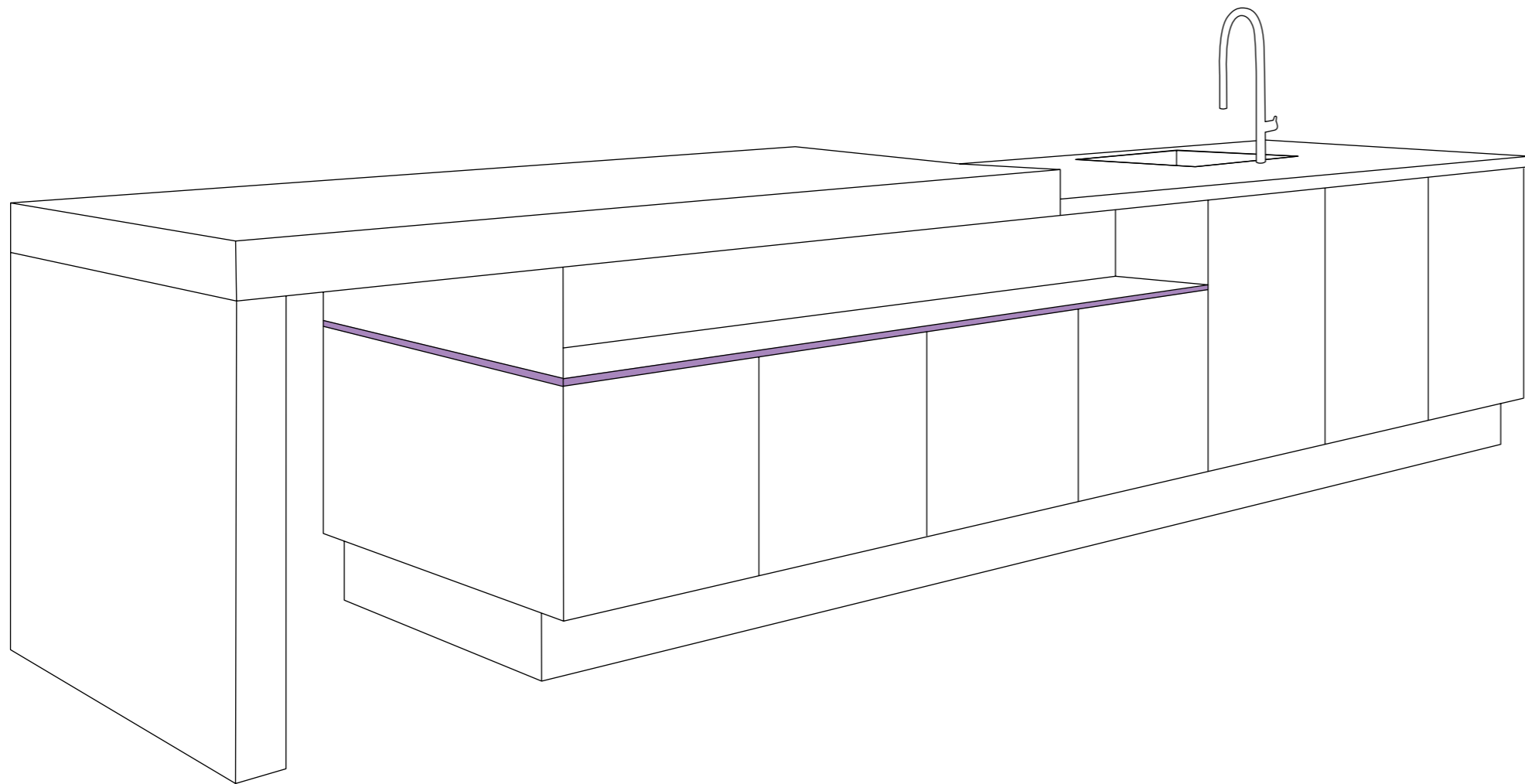

ARHandleless – Light profile for channel handle
 ART sin tirador – Perfil de gola de iluminación
 senza maniglie ART – Profilo luminoso per listello scanalato
 Systeme ART – Profil d'éclairage pour gorge



GB 'grifflosART' (without handles) means that cabinet panels are milled ready for assembly and the grooved strips are available in stainless steel coloured brushed, lava grey or matt white. The end of the strips can be optionally designed with front finishing frames.

ES En el grifflosART, los laterales del cuerpo están fresados listos para su montaje. Las molduras están disponibles en los colores acero inoxidable, lava gris y blanco mate. En la terminación de la línea hay la posibilidad de planificar los costados con terminación frontal.

IT Nella tipologia senza impugnatura, i lati del corpo vengono fresati già pronti per l'installazione e i listelli scanalati sono disponibili in color acciaio inox, grigio lava e bianco opaco. Sulla terminazione della linea è possibile inserire dei fianchi di chiusura frontale.

FR Chez grifflosART, les parties latérales du corps de cuisine sont fraisées de manière à être prêtes pour le montage ; les lattes de support sont disponibles en coloris acier et blanc mat. Il est possible de planifier la terminaison du bloc cuisine avec des joues.

Formed gable ends and pilaster
 Costados y panel lateral
 Spalle e montanti
 Jous et montant vertical

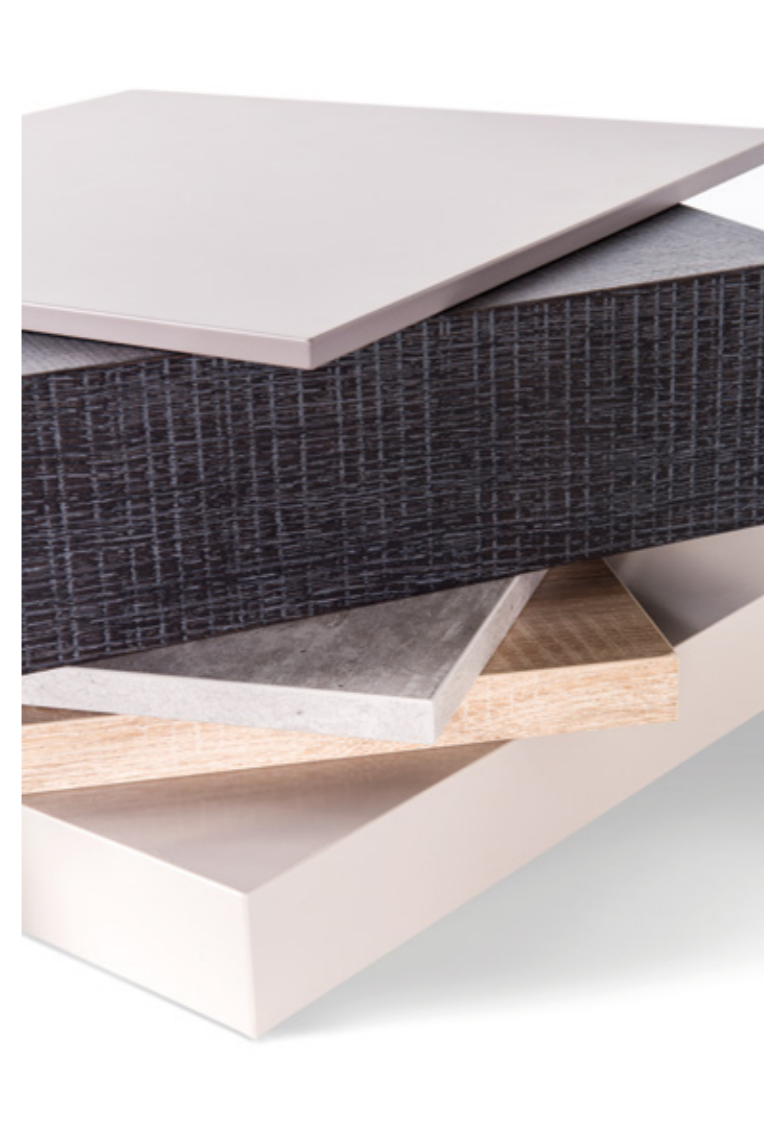

GB Gables and pilaster are available with various surfaces. You can choose the thickness for gables: 10, 16, 25, or 50 mm thick.

ES Los costados y paneles laterales están disponibles en diferentes superficies. Puede elegirse el espesor de los costados entre 10, 16, 25, ó 50 mm de espesor.

IT Spalle e montanti sono disponibili in diverse finiture. Per i spalle è possibile scegliere spessori da 10, 16, 25, o 50 mm.

FR Les joues et les montants sont disponibles dans différents revêtements de surface. Pour les joues, vous avez le choix entre plusieurs épaisseurs : 10, 16, 25, ou 50 mm.

Recess equipment Linero MosaiQ
 Equipamiento de entrepaño Linero MosaiQ
 Corredo per nicchie Linero MosaiQ
 Equipement de crédence Linero MosaiQ



GB The frame is in a stainless steel colour. There is a choice of accessories in lava grey or champagne. The frame can also be fitted with an integrated LED lighting system.

ES La barra es de color acero inoxidable. Los accesorios están disponibles a elegir en lava gris o champán. La barra puede equiparse adicionalmente con una iluminación led integrada.

IT L'asta è in color acciaio inox. Questo accessorio è disponibile anche in grigio lava o champagne e può essere integrato con illuminazione a LED.

FR La crédence de cuisine est de couleur acier. Les accessoires sont disponibles soit en gris lave soit en champagne. En outre, la crédence peut être équipée d'un éclairage LED intégré.

Lighting | Electronics

Illuminación | Electrónica
Illuminazione | Elettronica
Éclairage | Électronique

GB You can choose from a variety of lighting systems for planning. Many of the pull-outs and tilting systems can also be powered by electricity.

ES Durante la planificación tiene a disposición diferentes sistemas de luz. Además, muchos sistemas de cajones y giratorios pueden electrificarse.

IT Nella progettazione sono disponibili diversi sistemi di illuminazione. Inoltre, molti sistemi ad estrazione o orientabili possono essere elettrificati.

FR Lors de la planification, vous avez le choix entre différents systèmes d'éclairage. Par ailleurs, de nombreux systèmes télescopiques et basculants peuvent être dotés d'une fonction électrique.

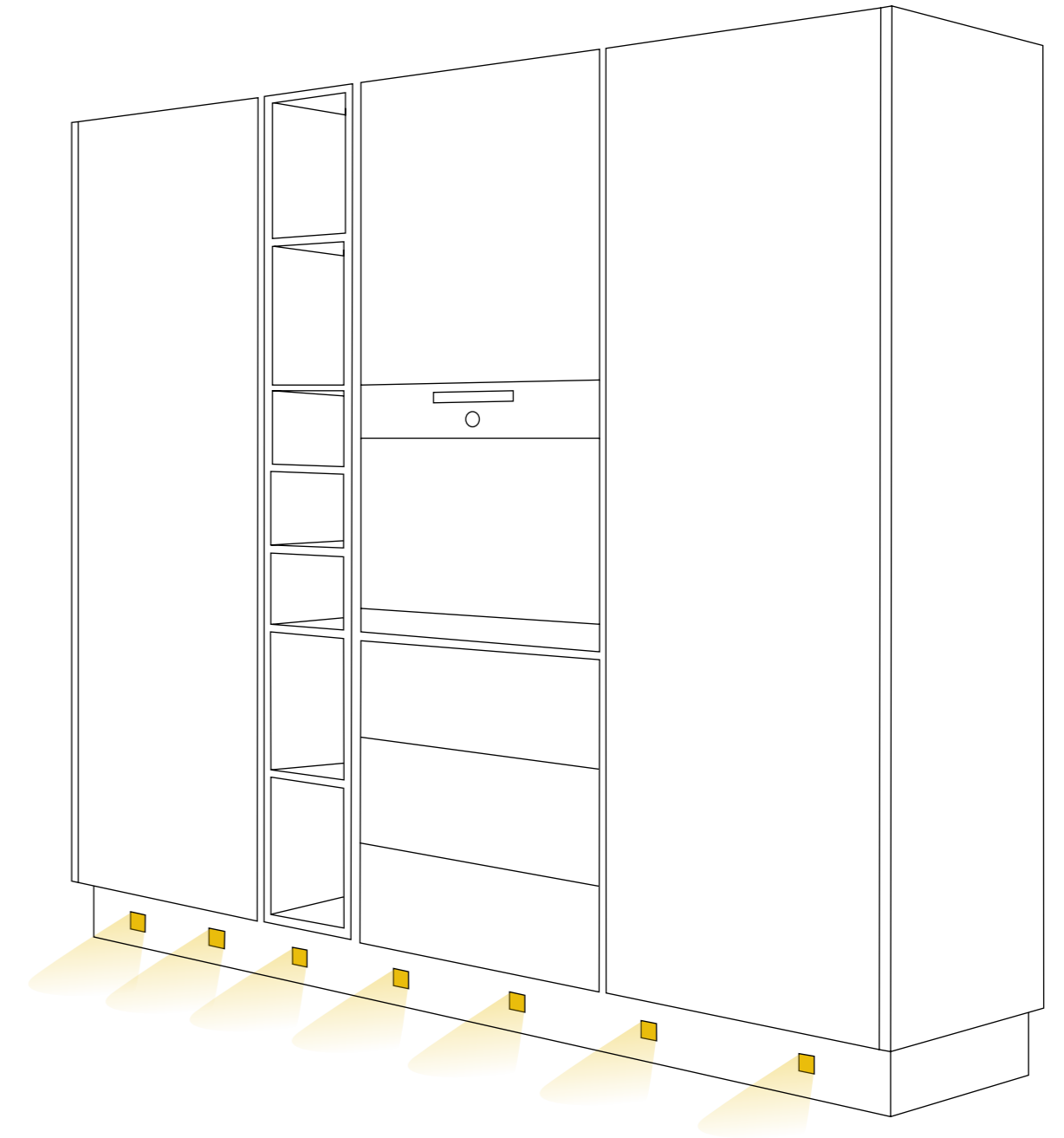
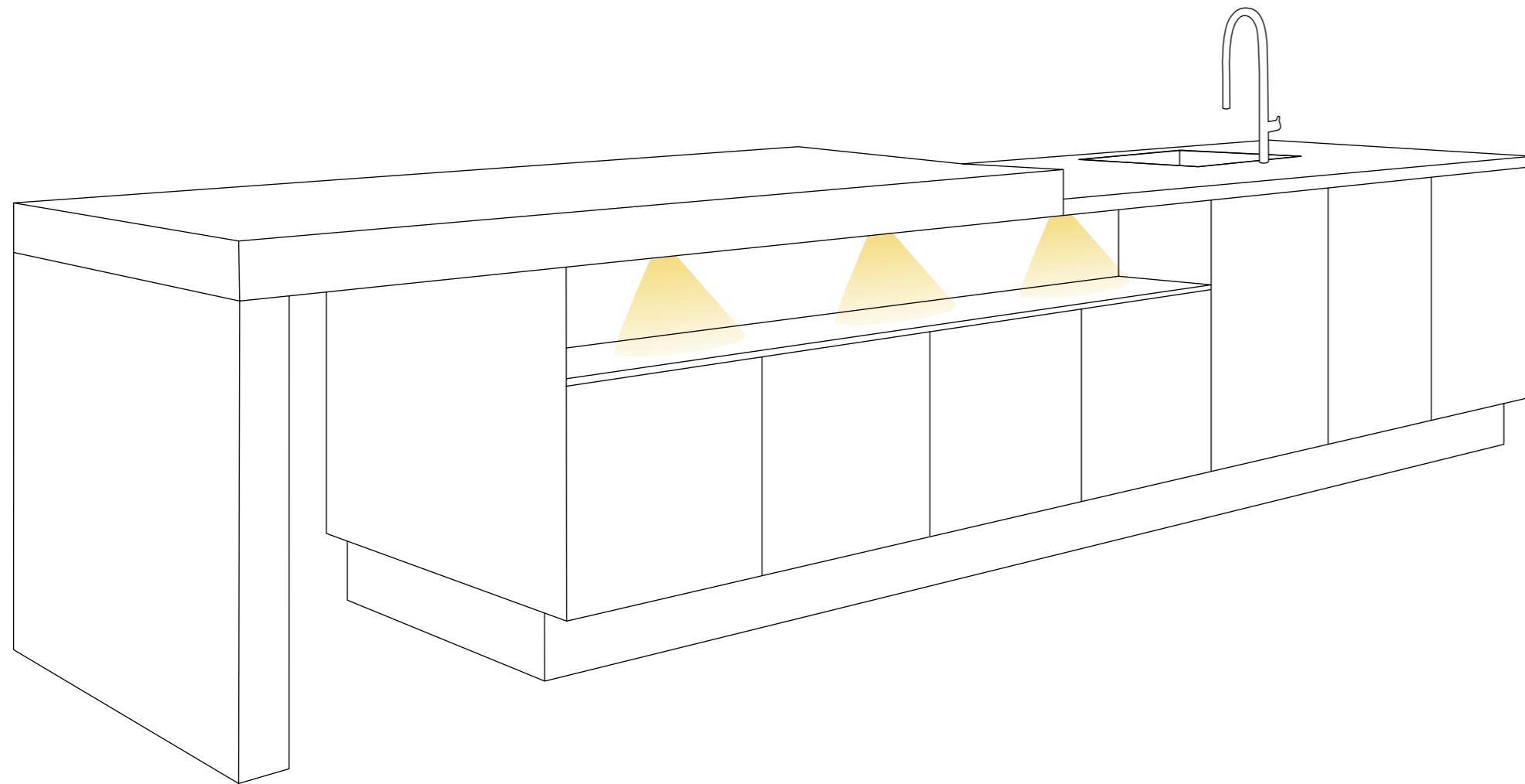

Wall unit with folding lift-up doors
 Armario alto con puertas plegables
 Pensile con anta a libro
 Élément mural avec portes pliantes



GB All swivel systems in wall units are designed to be adjusted continuously. They are easy to open and close softly. A wide range of planning options are available, as full furniture fronts or in combination with a framed front made from glass.

ES Todos los sistemas giratorios de los armarios altos están diseñados de manera que pueden ajustarse progresivamente. Se pueden abrir fácilmente y se cierran con suavidad gracias a un sistema de amortiguación. Tanto como frente completo de mueble como combinado con un frente de marco de cristal, usted dispone de una gran variedad de alternativas para la planificación.

IT Tutti i sistemi orientabili nei pensili alti sono progettati in modo che possano essere regolati in continuo. Si aprono facilmente e si chiudono con un sistema ammortizzante. Pannelli pieni o in combinazione con una cornice in vetro: è disponibile una vasta serie di progettazioni.

Wall unit with lift-up door
 Armario alto con puerta basculante
 Pensile con anta scorrevole
 Élément mural avec porte lift



Wall unit with flap door and illuminated base shelf LED
 Armario alto con puerta abatible y fondo luminoso LED
 Pensile con anta basculante e fondo illuminato LED
 Élément mural avec porte relevable et étagère inférieure à éclairage DEL



FR Tous les systèmes à bascule des éléments hauts sont réglables en continu. Ils sont faciles à ouvrir et équipés d'une fermeture amortie. Vous avez le choix entre de nombreuses variantes pour la conception de votre cuisine, qu'il s'agisse de façades pleines ou en combinaison avec une façade en verre avec cadre.

Wall unit with LED handle profile
 Armario alto con perfil tirador LED
 Pensile con profilo maniglia LED
 Élément mural avec profil de doigts lumineux DEL

Lighting systems
Sistemas de iluminación
Sistemi d'illuminazione
Systèmes d'éclairage

LED spot light with individual colour temperature change
Lámpara LED integrada con un cambio individual de la temperatura de color
Lampada LED da incasso con regolazione individuale della temperatura del colore
Spot encastrable DEL avec modification individuelle de la température de couleur



Lighting systems
Sistemas de iluminación
Sistemi d'illuminazione
Systèmes d'éclairage



GB Halogen or LED recessed luminaires can be used. The recess incl. cable outlet in the shelves are made in the factory.

ES También se pueden integrar focos LED o halógenos. El fresado con la salida de cables incluida en los estantes se realiza de fábrica.

IT Si possono impiegare lampade alogene o LED ad incasso. La fresatura e l'uscita del cavo nel suolo vengono effettuate in fabbrica.

FR Il est possible d'utiliser des halogènes ou des DEL encastrées. Le fraisage avec trou pour le passage des fils dans les étagères est effectué en usine.

LED plinth light
Iluminación de zócalo LED
Illuminazione LED per zoccolo
Eclairage DEL pour socle

Sound-System

Sensomatic

Servodrive

Climber

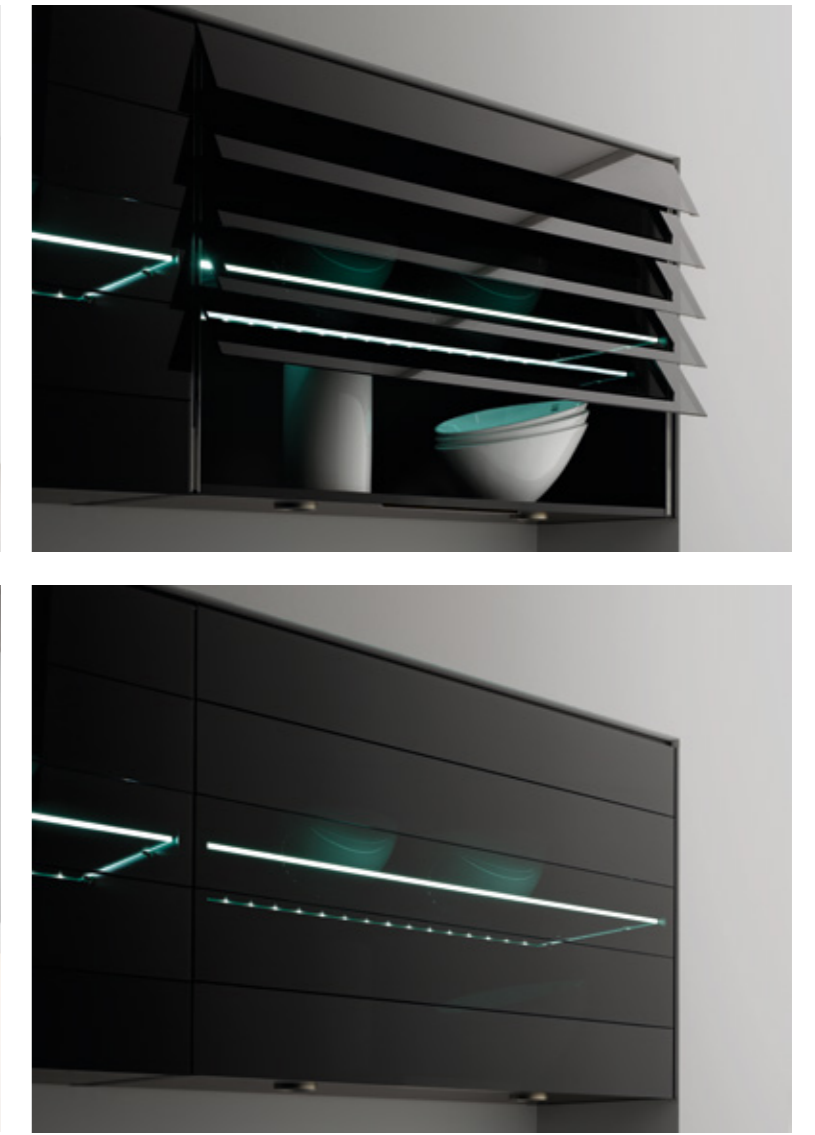
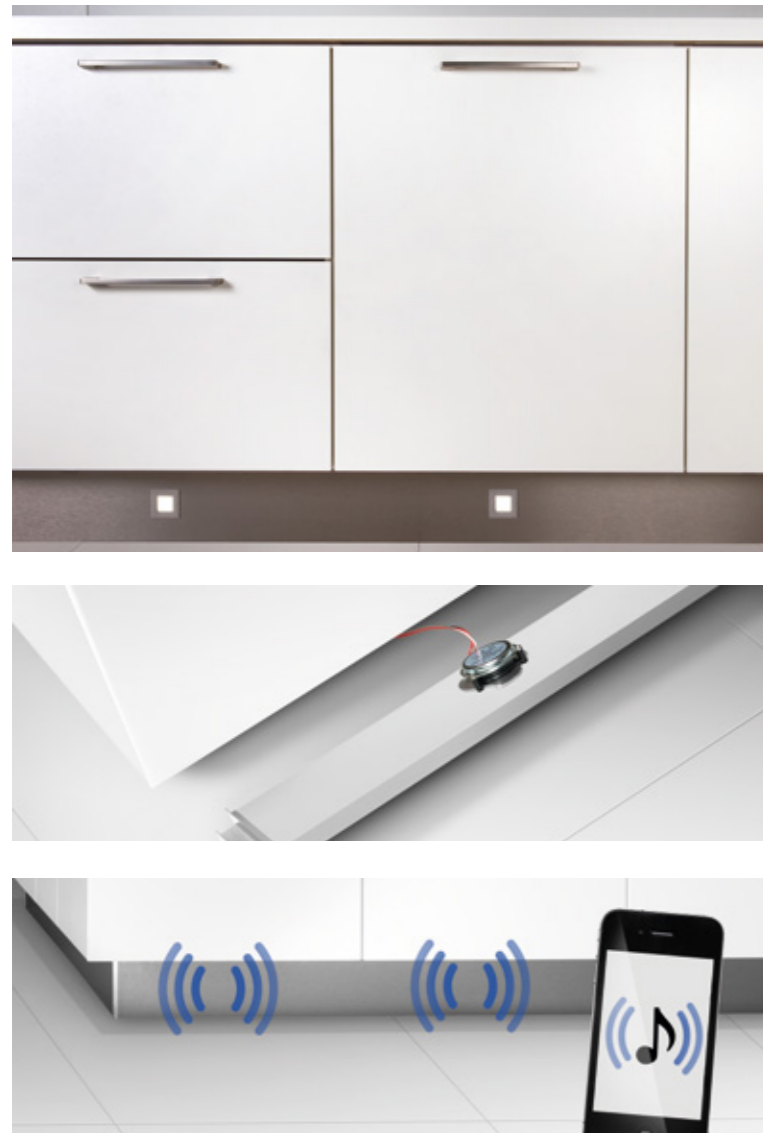

GB Sound system
Assembly recommendations behind
plinth panel
Operated via Bluetooth connection,
e.g. using a smartphone or tablet

IT Sound System
Montaggio consigliato dietro la fascia
zoccolo
Comandi attivabili tramite connessione
Bluetooth, per es. da smartphone/tablet

ES Sistema de sonido
Recomendación de montaje detrás del
zócalo
el manejo se realiza a través de conexión
Bluetooth por ejemplo, con el teléfono o
la tabla

FR Système sonore
Recommandation de montage derrière le
bandeau de socle
Fonctionnement par l'intermédiaire de la
connection Bluetooth par exemple via le
smartphone ou la tablette PC

GB Shutter, swivel door or the wall unit
climber can be connected to the power
supply and thus offer electronic support
when opening.

ES Tanto la tapa, la puerta giratoria
como el armario alto Climber pueden
electrificarse, por lo que ofrecen una
ayuda de apertura electrónica.

IT Sportello, porta orientabile e
prensile Climber possono essere quindi
elettrificati, fornendo così il vantaggio
di un'apertura elettronica.

FR Les portes relevables, les portes
basculantes ou les éléments hauts
« Climber » peuvent bénéficier d'une
fonction électrique offrant ainsi une
assistance électronique au niveau
de l'ouverture.

Front overview

Frentes – Visión de conjunto
Elenco modelli
Aperçu des façades

GB The variety of designs is second to none. You can freely choose and combine finishing materials. A large selection of designs is also available for 'grifflosART'.

ES La diversidad de muebles satisface todos los deseos. Puede elegir y combinar libremente los diferentes materiales. También se suministra una gran diversidad de los programas para el sistema ART sin asas.

IT La varietà di modelli disponibili non lascia alcun desiderio insoddisfatto. Potrete scegliere e combinare a piacimento i differenti materiali. Anche per la tipologia senza impugnature sono disponibili diversi programmi.

FR La diversité des meubles ne laisse aucun désir inassouvi. Vous pouvez librement choisir et combiner les différentes sortes de matériaux. De nombreuses gammes sont également disponibles pour grifflosART.

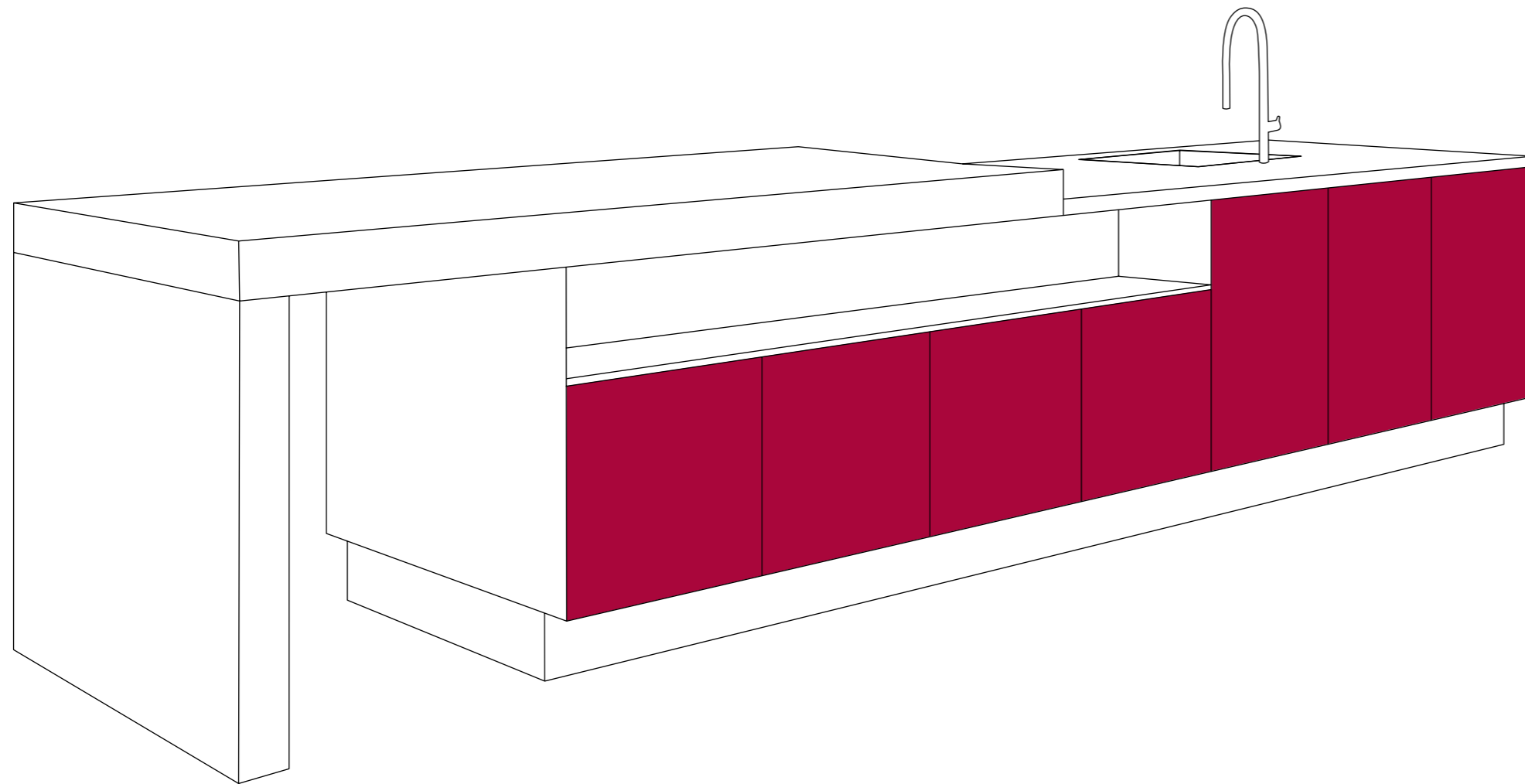

AV 1080 PG0 Laminate/fine structured | Material sintético/textura fina | laminato/struttura fine | Mèlaminée/structurée fine



White (ART)	Magnolia (ART)	Cashmere (ART)	Basalt grey (ART)	Orient red (ART)	Lava grey (ART)	Light grey (ART)
Bianco (ART)	Magnolia (ART)	Cachemir (ART)	Gris basalto (ART)	Rojo oriente (ART)	Lava gris (ART)	Gris luminoso (ART)
Bianco (ART)	Magnolia (ART)	Cachemire (ART)	Grigio basalto (ART)	Rosso oriente (ART)	Grigio lava (ART)	Grigio chiaro (ART)
Blanc (ART)	Magnolia (ART)	Cachemire (ART)	Gris basalte (ART)	Rouge oriental (ART)	Gris lave (ART)	Gris clair (ART)

AV 1030 PG0 Shiny laminate | Melamina brill. | Laminato lucido | Mèlaminé brillant



White (ART)	Magnolia (ART)	Cashmere (ART)	Basalt grey (ART)	Light acacia (ART)	Grey acacia (ART)	Terra oak (ART)	Natural oak rough-cut finish (ART)
Bianco (ART)	Magnolia (ART)	Cachemir (ART)	Gris basalto (ART)	Acacia luminoso (ART)	Acacia gris (ART)	Roble tierra (ART)	Roble natural aserrado carrasposo (ART)
Bianco (ART)	Magnolia (ART)	Cachemire (ART)	Grigio basalto (ART)	Acacia chiara (ART)	Acacia grigio (ART)	Quercia terra (ART)	Quercia natura ruvida (ART)
Blanc (ART)	Magnolia (ART)	Cachemire (ART)	Gris basalte (ART)	Acacia clair (ART)	Acacia gris (ART)	Chêne terra (ART)	Chêne naturel rugueux (ART)

AV 1095 PG1 Laminate matex surface | Melamina Matex | Laminato Matex | Mèlaminée/surface de matex



Light acacia rough-cut finish	Cornwall oak	Oak sand	Silk grey oak	Natural oak rough-cut finish	Nordic oak	Provence ash
Acacia luminoso asser. car.	Roble cornwall	Roble arena	Roble gris seda	Roble nat. aserrado carrasposo	Roble nórdico	Fresno provence
Acacia chiara ruvida	Quercia cornwall	Quercia sabbia	Quercia grigio seta	Quercia natura ruvida	Quercia nordica	Frassino provence
Acacia clair rugueux	Chêne cornwall	Chêne sable	Chêne gris soie	Chêne naturel rugueux	Chêne nordique	Frêne provence

AV 1092 PG2 Laminate matex plus surface | Melamina Matex plus | Laminato Matex plus | Mèlaminé/Matex Plus

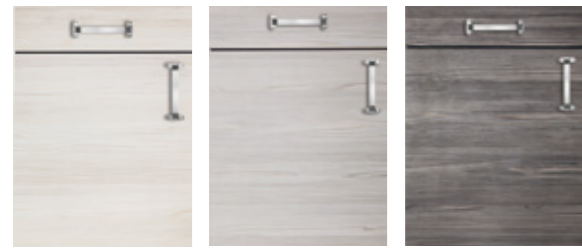

Light pine (ART)	Grey pine (ART)	Dark pine (ART)
Pino luminoso (ART)	Pino gris (ART)	Pino oscuro (ART)
Pino chiara (ART)	Pino grigio (ART)	Pino scuro (ART)
Pin clair (ART)	Pin gris (ART)	Pin foncé (ART)

AV 1010 PG2 Laminate/fine structured | Material sintético/textura fina | laminato/struttura fine | Mèlaminée/structurée fine



White	Magnolia
Bianco	Magnolia
Bianco	Magnolia
Blanc	Magnolia

AV 2030 PG2 High gloss lacquer | Lacado alto brillo | Laccato lucido brillante | Lustre laqué



Polar white (ART)	White (ART)	Magnolia (ART)	Taupe (ART)	Cashmere (ART)	Basalt grey (ART)	Pearl grey (ART)	Metallic carbon (ART)
Bianco polar (ART)	Bianco (ART)	Magnolia (ART)	Satén (ART)	Cachemir (ART)	Gris basalto (ART)	Gris perla (ART)	Carbono metálico (ART)
Bianco polare (ART)	Bianco (ART)	Magnolia (ART)	Satin (ART)	Cachemire (ART)	Grigio basalto (ART)	Grigio perla (ART)	Carbono metallico (ART)
Blanc polaire (ART)	Blanc (ART)	Magnolia (ART)	Satin (ART)	Cachemire (ART)	Gris basalte (ART)	Gris perle (ART)	Carbone métallisé (ART)

AV 2035 PG2 Satin lacquer | Laca mate satinada | Laccato opaco | Laque mate



Lava grey (ART)	Metallic ocean blue (ART)
Lava gris (ART)	Azul océano metálico (ART)
Grigio lava (ART)	Blu oceano metallico (ART)
Gris lave (ART)	Bleu océan métallisé (ART)

AV 2080 PG2 Laminate/fine structured | Material sintético/textura fina | laminato/struttura fine | Mèlaminée/structurée fine



Basalt grey (ART)	Pearl grey (ART)	Lava grey (ART)	Natural concrete (ART)	Salento grey beige (ART)	Terra (ART)
Gris basalto (ART)	Gris perla (ART)	Lava gris (ART)	Hormigón natural (ART)	Salento gris-beige (ART)	Tierra (ART)
Grigio basalto (ART)	Grigio perla (ART)	Grigio lava (ART)	Quercia natura (ART)	Salento grigio-beige (ART)	Terra (ART)
Gris basalte (ART)	Gris perle (ART)	Gris lave (ART)	Béton naturel (ART)	Salento gris beige (ART)	Terra (ART)

AV 3030 PG2 Laminated matt | Polilaminado mate | Rivestito polimerico opaco | Enveloppée d'un polymère mat



White	Magnolia
Bianco	Magnolia
Bianco	Magnolia
Blanc	Magnolia

AV 6000 PG3 Satin lacquer | Laca mate satinada | Laccato opaco | Laque mate



Polar white (ART)	White (ART)	Magnolia (ART)	Light grey (ART)
Bianco polar (ART)	Bianco (ART)	Magnolia (ART)	Gris luminoso (ART)
Bianco polare (ART)	Bianco (ART)	Magnolia (ART)	Grigio chiaro (ART)
Blanc polaire (ART)	Blanc (ART)	Magnolia (ART)	Gris clair (ART)

AV 6000 PG3 Satin lacquer | Laca mate satinada | Laccato opaco | Laque mate



Cashmere (ART)	Basalt grey (ART)	Agate blue (ART)	Lava grey (ART)	Pearl grey (ART)	Wine red (ART)	Black (ART)	Teal (ART)
Cachemir (ART)	Gris basalto (ART)	Ágata azul (ART)	Lava gris (ART)	Gris perla (ART)	Rojo vino (ART)	Negro (ART)	Petróleo (ART)
Cachemire (ART)	Grigio basalto (ART)	Agata blu (ART)	Grigio lava (ART)	Grigio perla (ART)	Rosso vino (ART)	Nero (ART)	Petrolio (ART)
Cachemire (ART)	Gris basalte (ART)	Bleu agate (ART)	Gris lave (ART)	Gris perle (ART)	Bordeaux (ART)	Noir (ART)	Pétrole (ART)

AV 4030 PG4 High gloss lacquer | Lacado alto brillo | Laccato lucido brillante | Lustre laqué



Golden yellow (ART)	Polar white (ART)	White (ART)	Brillant white (ART)	Magnolia (ART)	Light grey (ART)	Cashmere (ART)	Basalt grey (ART)
Amarillo dorado (ART)	Bianco polar (ART)	Bianco (ART)	Bianco diamante (ART)	Magnolia (ART)	Gris luminoso (ART)	Cachemir (ART)	Gris basalto (ART)
Giallo oro (ART)	Bianco polare (ART)	Bianco (ART)	Bianco lucido (ART)	Magnolia (ART)	Grigio chiaro (ART)	Cachemire (ART)	Grigio basalto (ART)
Jaune d'or (ART)	Blanc polaire (ART)	Blanc (ART)	Blanc étincelant (ART)	Magnolia (ART)	Gris clair (ART)	Cachemire (ART)	Gris basalte (ART)

AV 5025 PG4 High gloss lacquer | Lacado alto brillo | Laccato lucido | Lustre laqué brillante

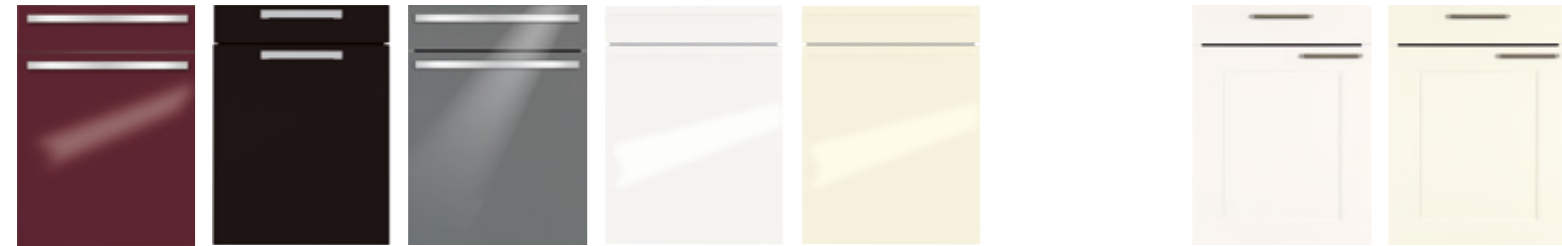

Wine red (ART)	Black (ART)	Lava grey (ART)	White	Magnolia	Polar white	White	
Rojo vino (ART)	Negro (ART)	Lava gris (ART)	Bianco	Magnolia	Bianco polar	Bianco	
Rosso vino (ART)	Nero (ART)	Grigio lava (ART)	Bianco	Magnolia	Bianco polare	Bianco	
Bordeaux (ART)	Noir (ART)	Gris lave (ART)	Blanc	Magnolia	Blanc polaire	Blanc	

AV 5007 PG5 Satin lacquer | Laca mate satinada | Laccato opaco | Laque mate



Magnolia	Light grey	Cashmere	Basalt grey	Pearl grey	Agate blue	Lava grey	Wine red
Magnolia	Gris luminoso	Cachemir	Gris basalto	Gris perla	Ágata azul	Lava gris	Rojo vino
Magnolia	Grigio chiaro	Cachemire	Grigio basalto	Grigio perla	Agata blu	Grigio lava	Rosso vino
Magnolia	Gris clair	Cachemire	Gris basalte	Gris perle	Bleu agate	Gris lave	Bordeaux

AV 5007 PG5 Satin lacquer | Laca mate satinada | Laccato opaco | Laque mate



Black	Teal	Golden yellow	White	Polar white	White
Negro	Petróleo	Amarillo dorado	Bianco	Bianco polar	Bianco
Nero	Petrolio	Giallo oro	Bianco	Bianco polare	Bianco
Noir	Pétrole	Jaune d'or	Blanc	Blanc polaire	Blanc

AV 5030 PG5 High gloss lacquer | Lacado alto brillo | Laccato lucido brillante | Lustre laqué



Magnolia	Light grey	Cashmere	Basalt grey	Pearl grey	Agate blue	Lava grey	Wine red
Magnolia	Gris luminoso	Cachemir	Gris basalto	Gris perla	Ágata azul	Lava gris	Rojo vino
Magnolia	Grigio chiaro	Cachemire	Grigio basalto	Grigio perla	Agata blu	Grigio lava	Rosso vino
Magnolia	Gris clair	Cachemire	Gris basalte	Gris perle	Bleu agate	Gris lave	Bordeaux

AV 5020 PG5 Satin lacquer | Laca mate satinada | Laccato opaco | Laque mate



Black	Teal	Golden yellow	Polar white	White	Magnolia	Cashmere	Light grey
Negro	Petróleo	Amarillo dorado	Bianco polar	Bianco	Magnolia	Cachemir	Gris luminoso
Nero	Petrolio	Giallo oro	Bianco polare	Bianco	Magnolia	Cachemire	Grigio chiaro
Noir	Pétrole	Jaune d'or	Blanc polaire	Blanc	Magnolia	Cachemire	Gris clair



Basalt grey	Pearl grey	Agate blue	Lava grey	Wine red	Black	Teal	Golden yellow
Gris basalto	Gris perla	Ágata azul	Lava gris	Rojo vino	Negro	Petróleo	Amarillo dorado
Grigio basalto	Grigio perla	Agata blu	Grigio lava	Rosso vino	Nero	Petrolio	Giallo oro
Gris basalte	Gris perle	Bleu agate	Gris lave	Bordeaux	Noir	Pétrole	Jaune d'or

AV 5090 PG6 Design glass | Cristal de diseño | Vetro design | Verre design

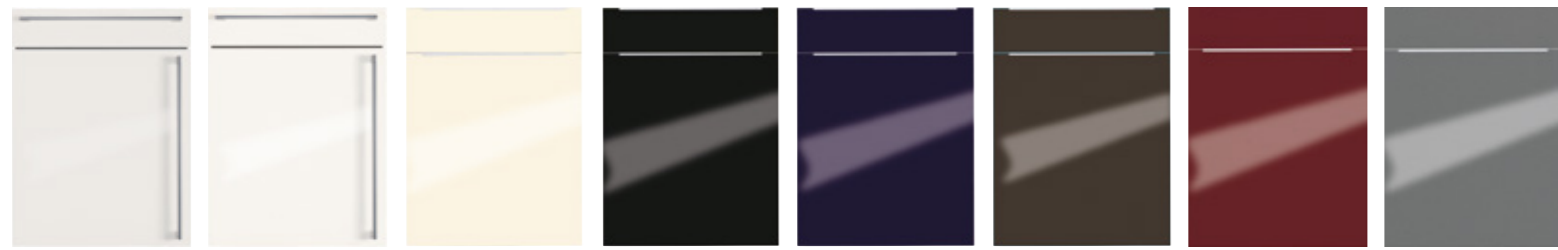

Brillant white (ART)	White (ART)	Magnolia (ART)	Black (ART)	Blackberry (ART)	Sepia brown (ART)	Wine red (ART)	Lava grey (ART)
Bianco diamante (ART)	Blanco (ART)	Magnolia (ART)	Negro (ART)	Mora (ART)	Sepia (ART)	Rojo vino (ART)	Lava gris (ART)
Bianco lucido (ART)	Bianco (ART)	Magnolia (ART)	Nero (ART)	Mora (ART)	Sepia marrone (ART)	Rosso vino (ART)	Grigio lava (ART)
Blanc étincelant (ART)	Blanc (ART)	Magnolia (ART)	Noir (ART)	Mûre (ART)	Brun sépia (ART)	Bordeaux (ART)	Gris lave (ART)

AV 5095 PG6 Design glass | Cristal de diseño | Vetro design | Verre design



Gold bronze metallic (ART)	Silver-grey metallic (ART)	White (ART)	Magnolia (ART)	Black (ART)	Blackberry (ART)	Sepia brown (ART)
Oro bronce metálico (ART)	Gris plata metálico (ART)	Blanco (ART)	Magnolia (ART)	Negro (ART)	Mora (ART)	Sepia (ART)
Oro bronce metálico (ART)	Grigio argento metálico (ART)	Bianco (ART)	Magnolia (ART)	Nero (ART)	Mora (ART)	Sepia marrone (ART)
Or bronze métallisé (ART)	Gris argenté métallisé (ART)	Blanc (ART)	Magnolia (ART)	Noir (ART)	Mûre (ART)	Brun sépia (ART)

AV 5080 PG6 Real wood veneer | Madera genuina chapada | Vero legno impiallacciato | Bois véritable plaqué



Wine red (ART)	Lava grey (ART)	Terra oak (ART)	Macassar ebony fineline (ART)	Maritime pine fineline (ART)	Ebony fineline (ART)
Rojo vino (ART)	Lava gris (ART)	Roble tierra (ART)	Ébano mac. fineline (ART)	Pino marítimo fineline (ART)	Ébano fineline (ART)
Rosso vino (ART)	Grigio lava (ART)	Quercia terra (ART)	Ebano mac. fineline (ART)	Pino marittimo fineline (ART)	Ebano fineline (ART)
Bordeaux (ART)	Gris lave (ART)	Chêne terra (ART)	Ébène mac. fineline (ART)	Pin maritime fineline (ART)	Ébène fineline (ART)

AV 5081 PG6 Real wood veneer brushed | Madera genuina chapada cepillado | Vero legno impiallacciato | Bois véritable plaqué brossé/spazzolato



Cinnamon oak pore structure (ART)	Grey oak pore structure (ART)	Silver oak pore structure (ART)	Sherry oak pore structure (ART)	Wild oak light (ART)	Wild oak grey (ART)	Wild oak brown (ART)	Sherry wild oak (ART)
Roble canela estructura de poros (ART)	Roble gris estructura de poros (ART)	Roble plateado estructura de poros (ART)	Roble jerez estructura de poros (ART)	Roble silvestre lum. (ART)	Roble silv. gris (ART)	Roble silv. marrón (ART)	Roble silvestre jerez (ART)
Quercia cannella struttura dei pori (ART)	Quercia grigio struttura dei pori (ART)	Quercia argentata struttura dei pori (ART)	Quercia sherry struttura dei pori (ART)	Quercia selv. chiara (ART)	Quercia selv. grigio (ART)	Quercia selv. marrone (ART)	Quercia selvatica sherry (ART)
Chêne cannelle poreux (ART)	Chêne gris poreux (ART)	Chêne argenté poreux (ART)	Chêne sherry poreux (ART)	Chêne sauv. clair (ART)	Chêne sauv. gris (ART)	Chêne sauv. brun (ART)	Chêne sauvage sherry (ART)

AV 5082 PG6 Real wood veneer brushed | Madera genuina chapada cepillado | Vero legno impiallacciato | Bois véritable plaqué brossé

AV 5083 PG6 Real wood veneer brushed | Madera genuina chapada cepillado | Vero legno impiallacciato spazzolato | Bois véritable plaqué brossé

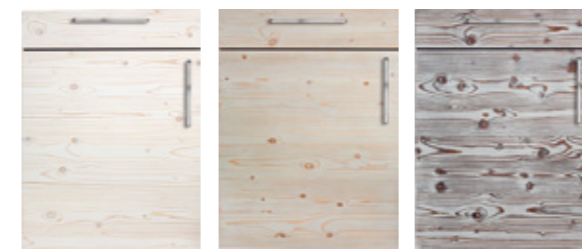

White pine (ART)	Natural pine (ART)	Dark pine (ART)
Pino blanco (ART)	Pino natural (ART)	Pino oscuro (ART)
Pino bianco (ART)	Pino natura (ART)	Pino scuro (ART)
Pin blanc (ART)	Pin naturel (ART)	Pin foncé (ART)

AV 6020 PG6 Real wood veneer brushed | Madera genuina chapada cepillado | Vero legno impiallacciato | Bois véritable plaqué brossé spazzolato



Grey oak pore structure	Cinnamon oak pore structure	Silver oak pore structure	Sherry oak pore structure
Roble gris estructura de poros	Roble canela estructura de poros	Roble plateado est. de poros	Roble jerez estr. de poros
Quercia grigio struttura dei pori	Quercia cannella struttura dei pori	Quercia argentata struttura dei pori	Quercia sherry struttura dei pori
Chêne gris poreux	Chêne cannelle poreux	Chêne argenté poreux	Chêne sherry poreux

AV 6021 PG6 Real wood veneer rough-cut finish | Madera genuina chapada aserrado carrasposo | Vero legno impiallacciato ruvido | Bois véritable plaqué rugueux



White oak (ART)	Magnolia oak (ART)	Natural oak (ART)	Platinum oak (ART)	Silver oak (ART)	Black oak (ART)
Roble blanco (ART)	Roble magnolia (ART)	Roble natural (ART)	Roble platino (ART)	Roble plateado (ART)	Roble negro (ART)
Quercia bianco (ART)	Quercia magnolia (ART)	Quercia naturale (ART)	Quercia platino (ART)	Quercia argentato (ART)	Quercia nero (ART)
Chêne blanc (ART)	Chêne magnolia (ART)	Chêne naturel (ART)	Chêne platine (ART)	Chêne argenté (ART)	Chêne noir (ART)

AV 6035 PG6 Ash lacquer real wood frame veneered center panel | fresno lacado marco macizo plafón chapado | frassino laccato telaio massiccio pannello impiallacciato | Frêne laqué cadre massif panneau plaqué



White	Magnolia	Saffron yellow	Cashmere	Pearl grey	Lava grey	Crimson red	Agate blue
Blanco	Magnolia	Azafrán	Cachemir	Gris perla	Lava gris	Rojo carmín	Agata azul
Bianco	Magnolia	Giallo zafferano	Cachemire	Grigio perla	Grigio lava	Rosso carminio	Agata blu
Blanc	Magnolia	Jaune safran	Cachemire	Gris perle	Gris lave	Rouge carmin	Bleu agate

AV 7030 PG7 Stone veneered | Piedra chapada | Struttura pietra | Pierre plaquée

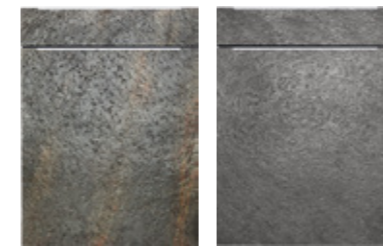

Gold Green (ART)	Black Star (ART)
Gold Green (ART)	Black Star (ART)
Gold Green (ART)	Black Star (ART)
Gold Green (ART)	Black Star (ART)

AV 6080 PG8 Real wood veneer high gloss lacquer | Madera genuina chapada lacado alto brillo | Vero legno impiallacciato laccato lucido brillante | Bois véritable plaqué lustre laqué

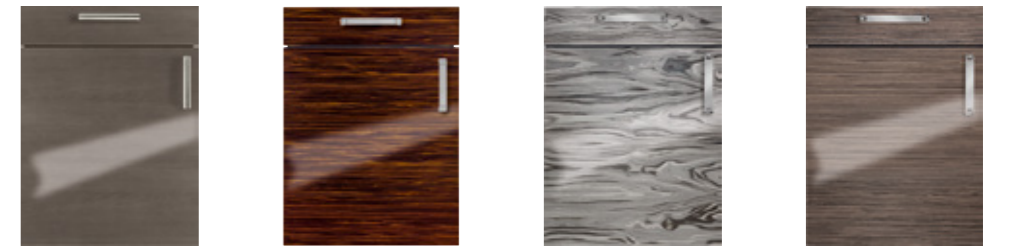

Terra oak (ART)	Macassar ebony fineline (ART)	Maritime pine fineline (ART)	Ebony fineline (ART)
Roble tierra (ART)	Ébano mac. fineline (ART)	Pino marítimo fineline (ART)	Ébano fineline (ART)
Quercia terra (ART)	Ébano mac. fineline (ART)	Pino marittimo fineline (ART)	Ébano fineline (ART)
Chêne terra (ART)	Ébène mac. fineline (ART)	Pin maritime fineline (ART)	Ébène fineline (ART)

Worktops

Encimeras
Piani di lavoro
Plans de travail

GB You can choose between synthetic, and natural stone finishes for worktops. Many finishes with different thickness are also available.

ES Las encimeras están disponibles en plástico o piedra natural. También hay disponibles muchas variantes en diferentes espesores.





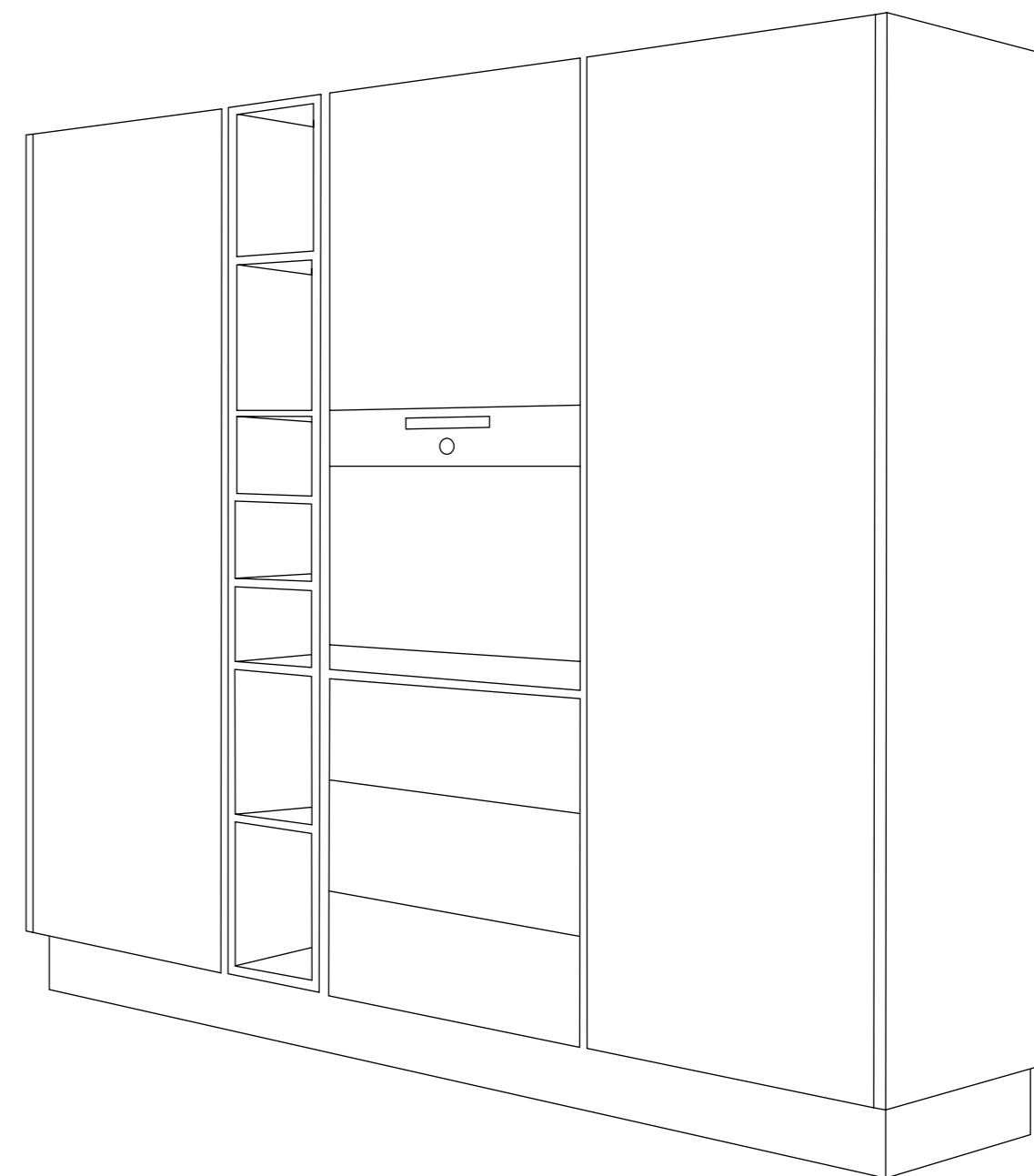
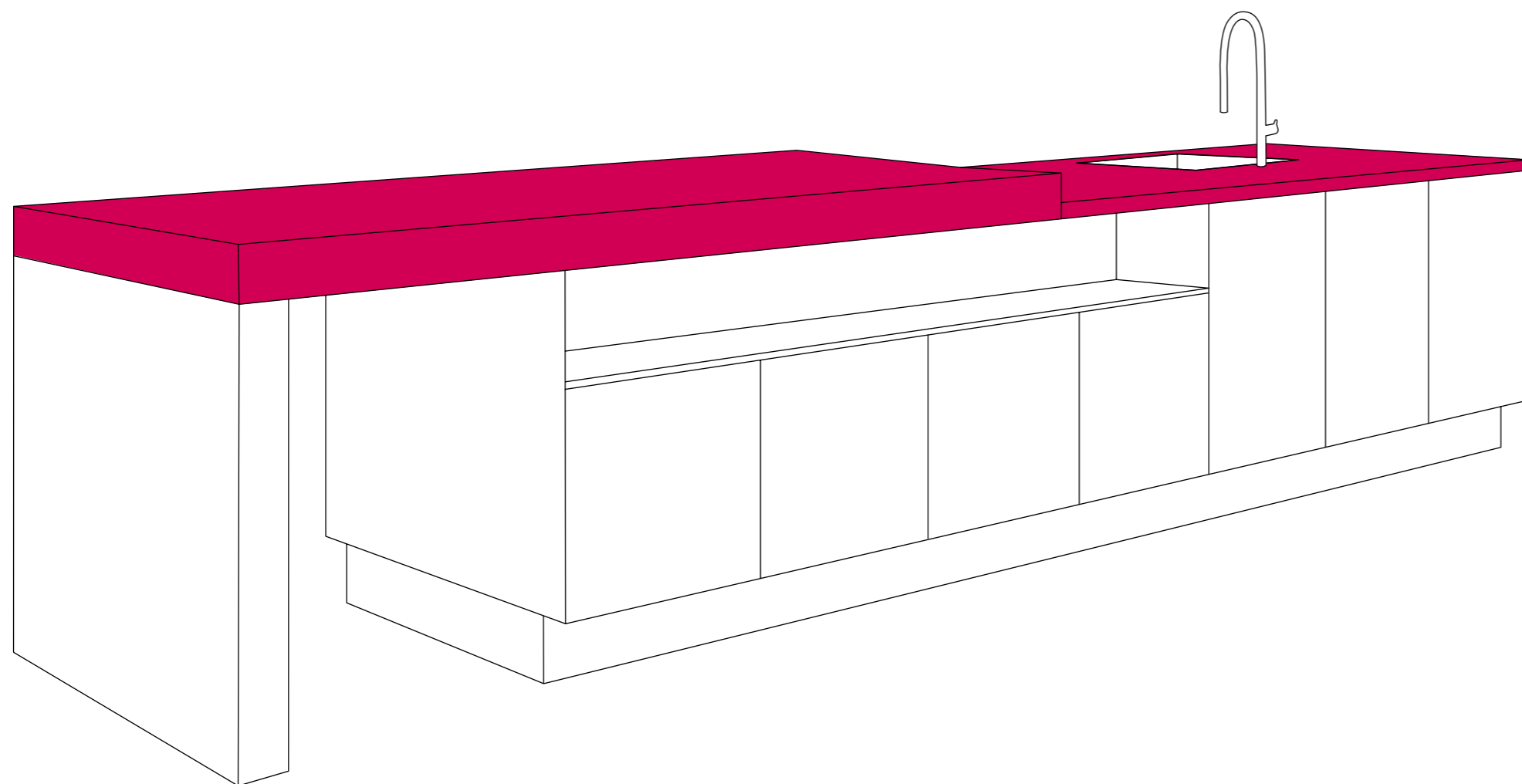

















IT I piani di lavoro sono disponibili in materiale plastico o pietra naturale. Le molteplici varianti sono presenti anche in diverso spessore.







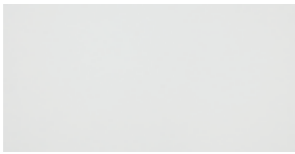
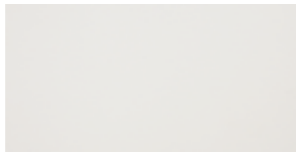







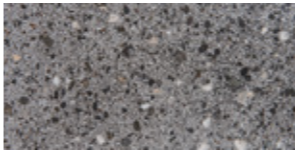

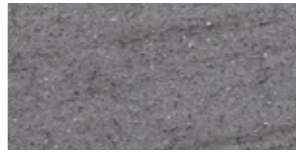

FR Pour les plans de travail, vous avez le choix entre une finition mélaminée, en bois massif ou en pierre naturelle. De plus, de nombreuses finitions sont disponibles en différentes épaisseurs.

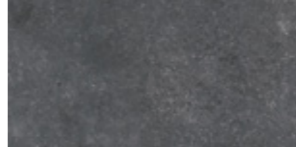

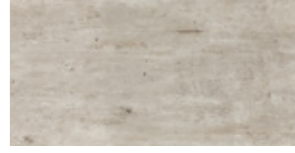
Worktops
Encimeras

Piani di lavoro
Plans de travail

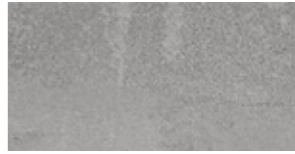
93	40	80	09	16
				
Nordic larch Lárice nórdica Larice nordico Mélèze nordique	Light acacia Acacia luminosa Acacia chiara Acacia clair	Grey acacia Acacia gris Acacia grigio Acacia gris	Core wood Duramen Durame Coeur du bois	Noble beech Haya noble Faggio pregiato Hêtre noble
17	97	18	32	34
				
Provence ash Fresno provence Frassino provence Frêne provence	Walnut Nogal Noce Noyer	Arizona pine Pino arizona Pino arizona Pin arizona	Pine vintage Pino vintage Pino vintage Pin vintage	Pine chalet Pino chalet Pino chalet ripro Pin chalet
104	88	08	77	37
				
Natural aok rough-cut finish Roble natural aserrado carrasposo Quercia natura ruvido Chêne naturel rugueux	Cornwall oak Roble cornwall Quercia cornwall Chêne cornwall	Silk grey oak Roble gris seda Quercia grigio seta Chêne gris soie	Mountain spruce Abeto rojo montaña Abete rosso di montagna Sapin de montagne	Wenge Wenge Wengé Wengé
91	76	28	25	
				
Core oak Roble duramen Rovere durame Coeur de chêne	Barrique oak Roble barrique Quercia barrique Chêne-barrique	Terra oak Roble tierra Quercia terra Chêne terra	Oak sand Roble arena Quercia sabbia Chêne sable	
22	79	85	87	94
				
Stone structure polar white Estructurada de piedra blanco polar Bianco polare struttura pietra Blanc polaire structure en pierre	Stone structure white Estructurada de piedra blanco Bianco struttura pietra Blanc structure en pierre	Stone structure magnolia Estructurada de piedra magnolia Magnolia struttura pietra Magnolia structure en pierre	Stone structure cashmere Estructurada de piedra cachemir Cachemire struttura pietra Cachemire structure en pierre	Stone structure basalt grey Estructurada de piedra gris basalto Grigio basalto struttura pietra Gris basalte structure en pierre

23	13	57	36	43
				
Stone structure lava grey Estructurada de piedra gris lava Grigio lava struttura pietra Gris lave structure en pierre	Carrara white Carrara blanco Carrara bianco Carrara blanc	Jura marble Jura mármol Jura marmo Jura marbre	Caledonia Caledonia Caledonia Caledonia	Salento grey beige Salento beige gris Salento grigio beige Salento gris beige
35	11	14	24	29
				
Palio quartz grey Palio cuarzo gris Palio quarzo grigio Palio gris quartz	Light vesuv Vesuv luminoso Vesuv chiara Vesuv clair	Dark vesuv Vesuv oscuro Vesuv scuro Vesuv foncé	Marble black Mármol negro Marmo nero Marbre noir	Granite black Granito negro Granito negro Granit noir
84	26	21	70	96
				
Metallo Metallo Metallo Metallo	Terra Tierra Terra Terra	Soap stone mouse grey Esteatita gris ceniza Steatite grigio topo Stéatite gris souris	Paros dark Paros oscuro Paros scuro Paros foncé	Natural concrete Hormigón natural Calcestruzzo natura Béton naturel
53	60	54	39	27
				
Light concrete Hormigón luminoso Calcestruzzo chiaro Béton clair	Grey concrete Hormigón gris Calcestruzzo grigio Béton gris	Dark concrete Hormigón oscuro Calcestruzzo cupo Béton foncé	Putty concrete pearl grey Hormigón enfoscado gris perla Calcestruzzo spatolato grigio perla Béton spatulé gris perle	Mica slate Micacita Micascisto Micaschiste

Natural stone
Piedra natural

Pietra naturale
Pierre naturelle

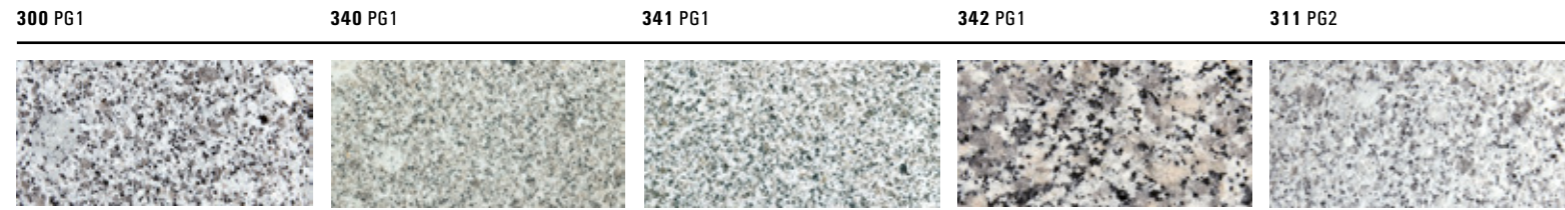

Bianco Cristall polished	Hintertiessen patinato	Hintertiessen polished	Rosa Beta polished	Bianco Cristall antique
Bianco Cristall pulido	Hintertiessen patinado	Hintertiessen pulido	Rosa Beta pulido	Bianco Cristall antiguo
Bianco Cristall lucido	Hintertiessen patinato	Hintertiessen lucido	Rosa Beta lucido	Bianco Cristall antico
Bianco Cristall poli	Hintertiessen patinato	Hintertiessen poli	Rosa Beta poli	Bianco Cristall antique

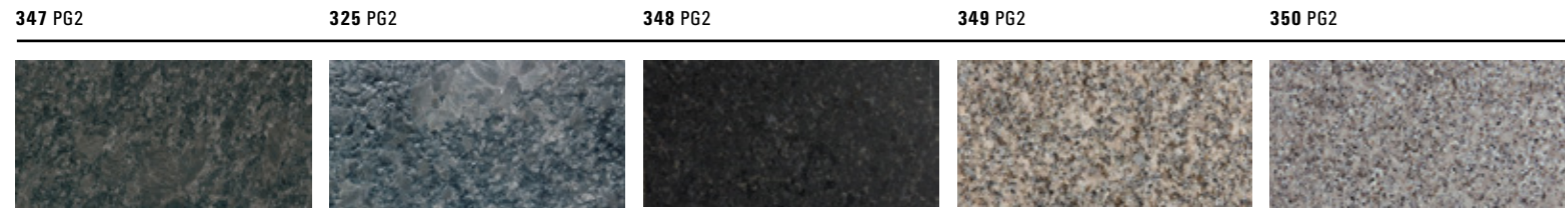

Steel Grey polished	Steel Grey satin	Tiger Black smoothed	Bohus Grey polished	Bohus Grey satin
Steel Grey pulido	Steel Grey satinado	Tiger Black lijado	Bohus Grey pulido	Bohus Grey satinado
Steel Grey lucido	Steel Grey satinato	Tiger Black levigato	Bohus Grey lucido	Bohus Grey satinato
Steel Grey poli	Steel Grey satiné	Tiger Black taillée	Bohus Grey poli	Bohus Grey satiné

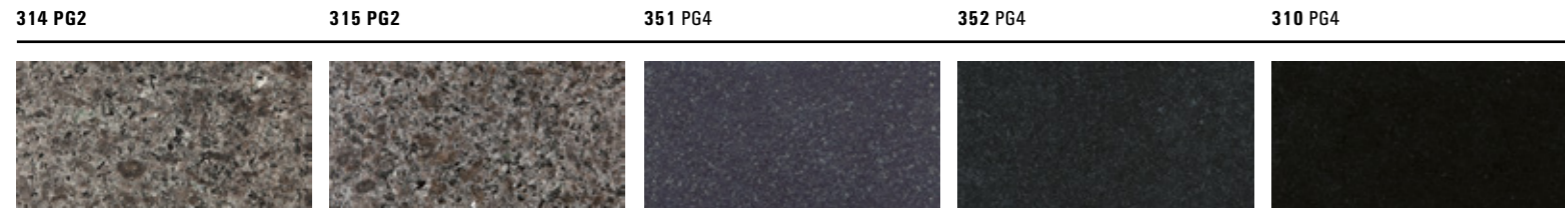

Silver Coffee satin	Silver Coffee polished	Nero Assoluto waterjet	Nero Assoluto smoothed	Nero Assoluto polished
Silver Coffee satinado	Silver Coffee pulido	Nero Assoluto waterjet	Nero Assoluto lijado	Nero Assoluto pulido
Silver Coffee satinato	Silver Coffee lucido	Nero Assoluto waterjet	Nero Assoluto levigato	Nero Assoluto lucido
Silver Coffee satiné	Silver Coffee poli	Nero Assoluto waterjet	Nero Assoluto taillée	Nero Assoluto poli



Phyllit Black satin	Silver Moon patinato	Silver Moon polished	Silver Moon Uni mottled	Silver Moon Uni patinato
Phyllit Black satinado	Silver Moon patinado	Silver Moon pulido	Silver Moon Uni flameado	Silver Moon Uni patinado
Phyllit Black satinato	Silver Moon patinato	Silver Moon lucido	Silver Moon Uni fiammata	Silver Moon Uni patinato
Phyllit Black satiné	Silver Moon patinato	Silver Moon poli	Silver Moon Uni ondulé	Silver Moon Uni patinato

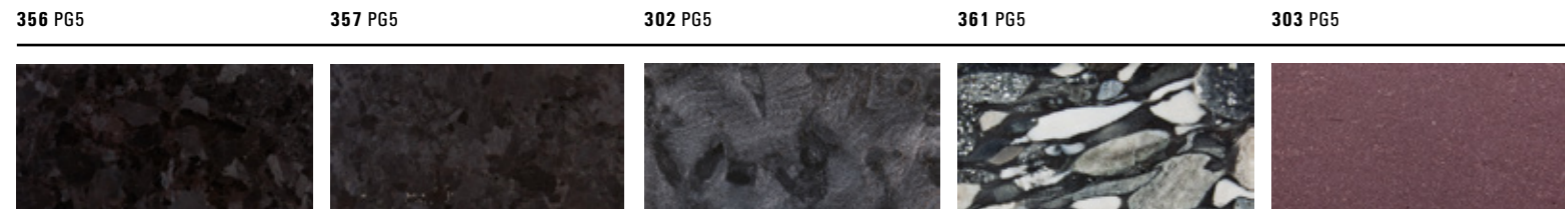

Antique Brown polished	Antique Brown satin	Matrix smoothed	Nero Marinace satin	Porphyr Valcamonica satin
Antique Brown pulido	Antique Brown satinado	Matrix lijado	Nero Marinace satinado	Porphyr Valcamonica satinado
Antique Brown lucido	Antique Brown satinato	Matrix levigato	Nero Marinace satinato	Porphyr Valcamonica satinato
Antique Brown poli	Antique Brown satiné	Matrix taillée	Nero Marinace satiné	Porphyr Valcamonica satiné

Quartz stone
Piedra de cuarzo

Pietra di quarzo
Pierre de quartz



Gris Expo polished	Beach Dark Grey polished	Beach Iceberg polished	Beach Taupe polished	Belgium Blue polished
Gris Expo pulido	Beach Dark Grey pulido	Beach Iceberg pulido	Beach Taupe pulido	Belgium Blue pulido
Gris Expo lucido	Beach Dark Grey lucido	Beach Iceberg lucido	Beach Taupe lucido	Belgium Blue lucido
Gris Expo poli	Beach Dark Grey poli	Beach Iceberg poli	Beach Taupe poli	Belgium Blue poli



Negro Tebas polished	Premium Cobalt Grey polished	Premium Cuba Brown polished	Premium Dolphin Grey polished	Pure White polished
Negro Tebas pulido	Premium Cobalt Grey pulido	Premium Cuba Brown pulido	Premium Dolphin Grey pulido	Pure White pulido
Negro Tebas lucido	Premium Cobalt Grey lucido	Premium Cuba Brown lucido	Premium Dolphin Grey lucido	Pure White lucido
Negro Tebas poli	Premium Cobalt Grey poli	Premium Cuba Brown poli	Premium Dolphin Grey poli	Pure White poli

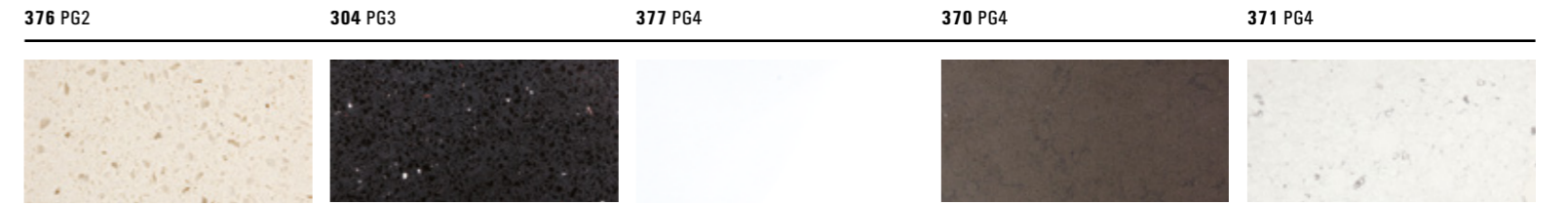

Risotto Crema polished	Starlight Black polished	Supreme White polished	Amazon polished	Bianco River polished
Risotto Crema pulido	Starlight Black pulido	Supreme White pulido	Amazon pulido	Bianco River pulido
Risotto Crema lucido	Starlight Black lucido	Supreme White lucido	Amazon lucido	Bianco River lucido
Risotto Crema poli	Starlight Black poli	Supreme White poli	Amazon poli	Bianco River poli

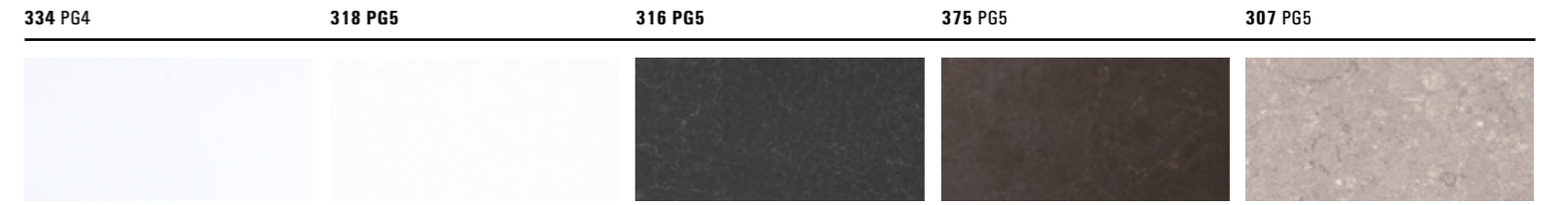

Blanco Zeus polished	Perfect White polished	Plata Grey polished	Merope polished	Shitake polished
Blanco Zeus pulido	Perfect White pulido	Plata Grey pulido	Merope pulido	Shitake pulido
Blanco Zeus lucido	Perfect White lucido	Plata Grey lucido	Meropelucido	Shitake lucido
Blanco Zeus poli	Perfect White poli	Plata Grey poli	Merope poli	Shitake poli



London Grey polished
London Grey pulido
London Grey lucido
London Grey poli

Ceramic
Cerámico

Ceramica
Céramique

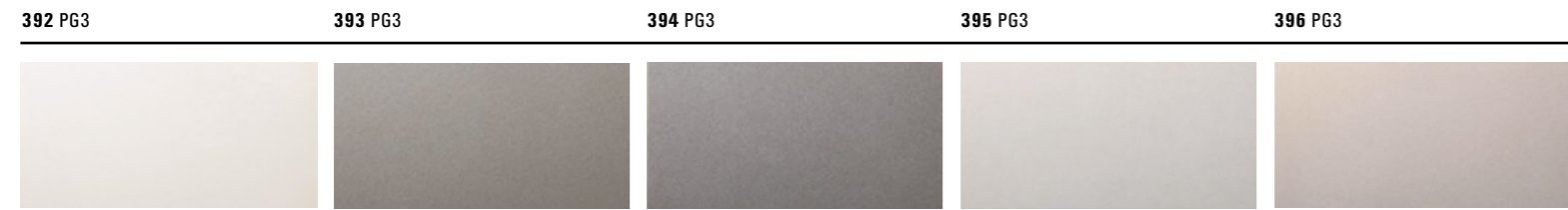

Blanco Plus	Gris	Plomo	Piedra	Camel
Blanco Plus	Gris	Plomo	Piedra	Camel
Blanco Plus	Gris	Plomo	Piedra	Camel
Blanco Plus	Gris	Plomo	Piedra	Camel



Marengo	Crema	Negro	Crema Marifil	Basalt Beige
Marengo	Crema	Negro	Crema Marifil	Basalt Beige
Marengo	Crema	Negro	Crema Marifil	Basalt Beige
Marengo	Crema	Negro	Crema Marifil	Basalt Beige

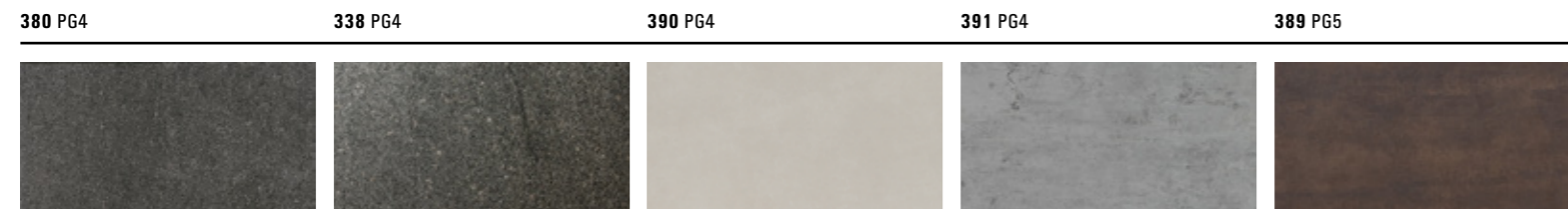

Basalt Black	Basalt Grey	Phedra	Beton	Iron Moss
Basalt Black	Basalt Grey	Phedra	Beton	Iron Moss
Basalt Black	Basalt Grey	Phedra	Beton	Iron Moss
Basalt Black	Basalt Grey	Phedra	Beton	Iron Moss



Pulpis
Pulpis
Pulpis
Pulpis

Handles

Tiradores
Maniglie
Poignées

GB There are many handle systems, apart from knobs and grips, which are supplied to match cabinet widths.

ES Además de botones y tiradores, hay muchos sistemas de agarre, que se suministran conforme a las anchuras del armario.

IT Oltre a pomelli e maniglie, sono possibili tanti sistemi di impugnatura, abbinabili in base alla larghezza del mobile.

FR Outre les boutons et les poignées, il existe une multitude de systèmes de poignées livrées en fonction de la largeur du meuble.

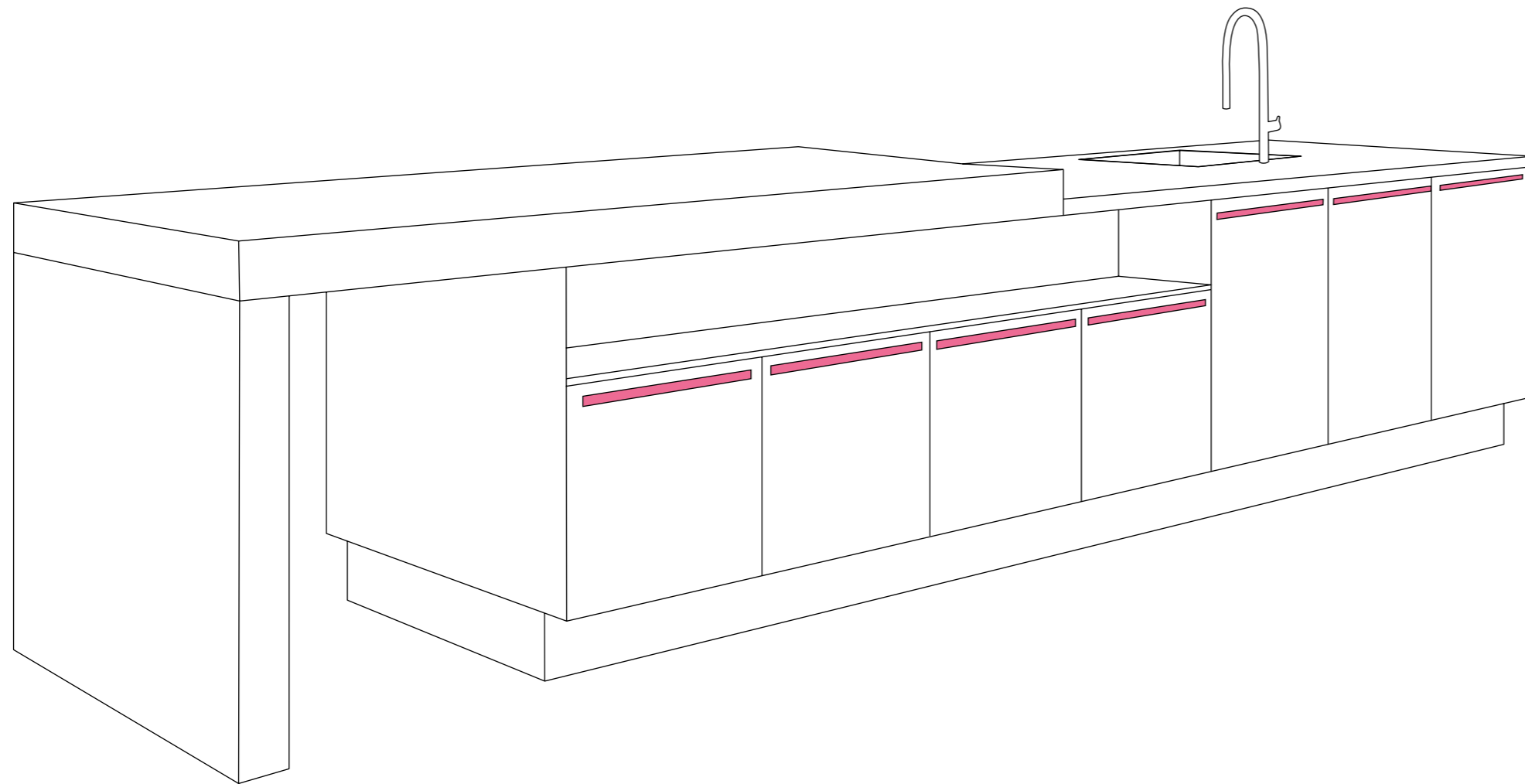



367

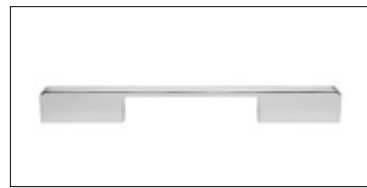

346



428



438

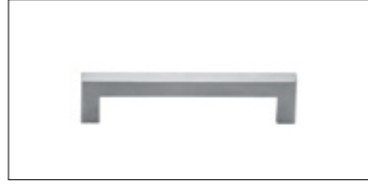

356



441



452



471

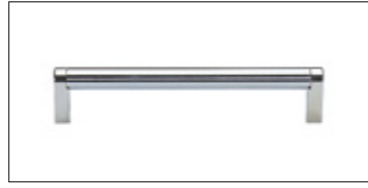

534

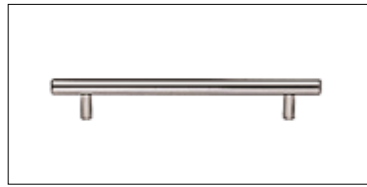

330



336

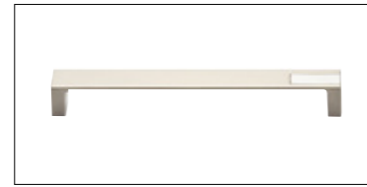

339

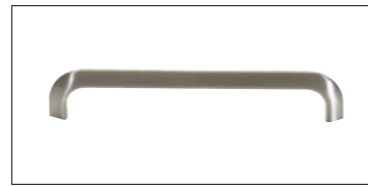

348



352

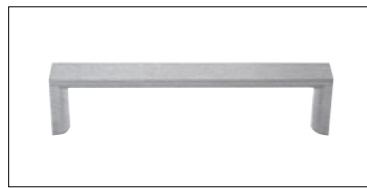

430

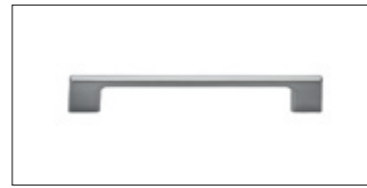

357

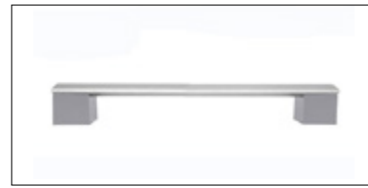

495

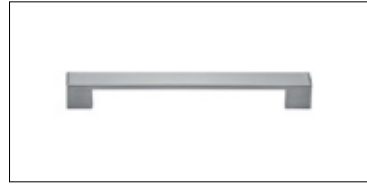

436

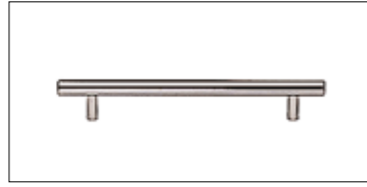

570

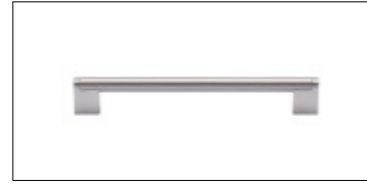

439

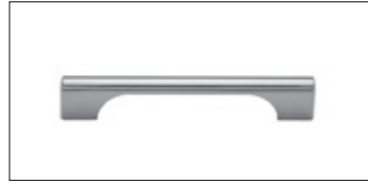

544



M 547

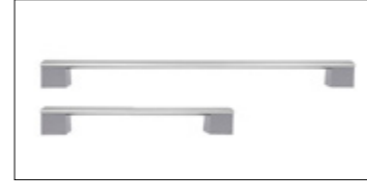

M 551

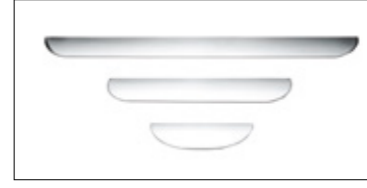

B 615

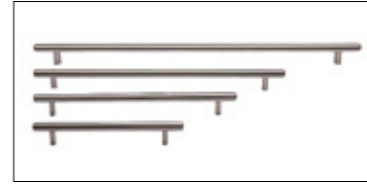

B 550

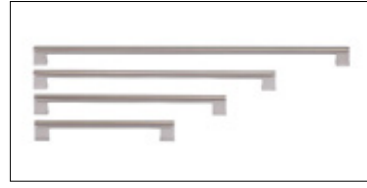

M 530

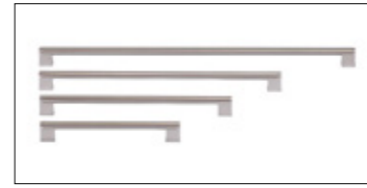

M 542

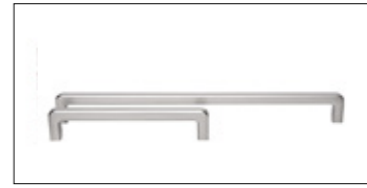

M 537

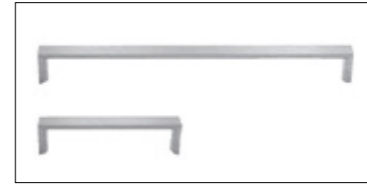

M538

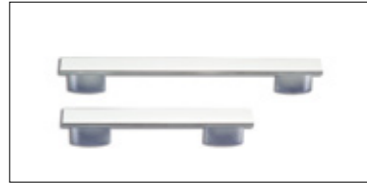

M 539

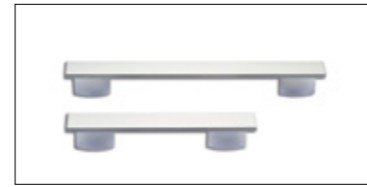

M 546

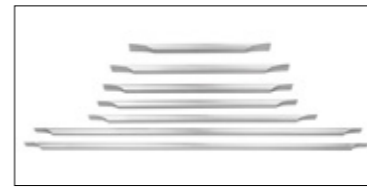

M 700



M 720



M 725

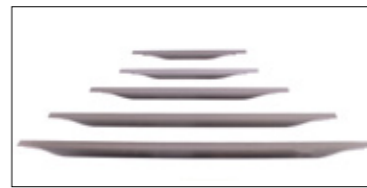

M 740

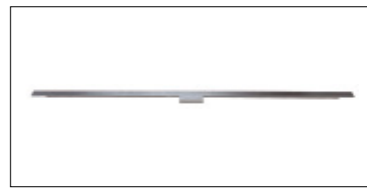

DV 1



Material Science

Ciencia de materiales
Informazioni sul materiale
Etude des matériaux

GB We use various materials for making kitchen furniture. You will find an overview on the following pages.

ES En la producción de muebles de cocina empleamos diferentes materiales. Encontrará una sinopsis en las páginas siguientes.

IT Per la produzione dei mobili da cucina utilizziamo materiali diversi. Nelle pagine successive è disponibile una panoramica.

FR Nous utilisons des matériaux différents dans la production des meubles de cuisine. Vous trouverez une vue d'ensemble dans les pages suivantes.

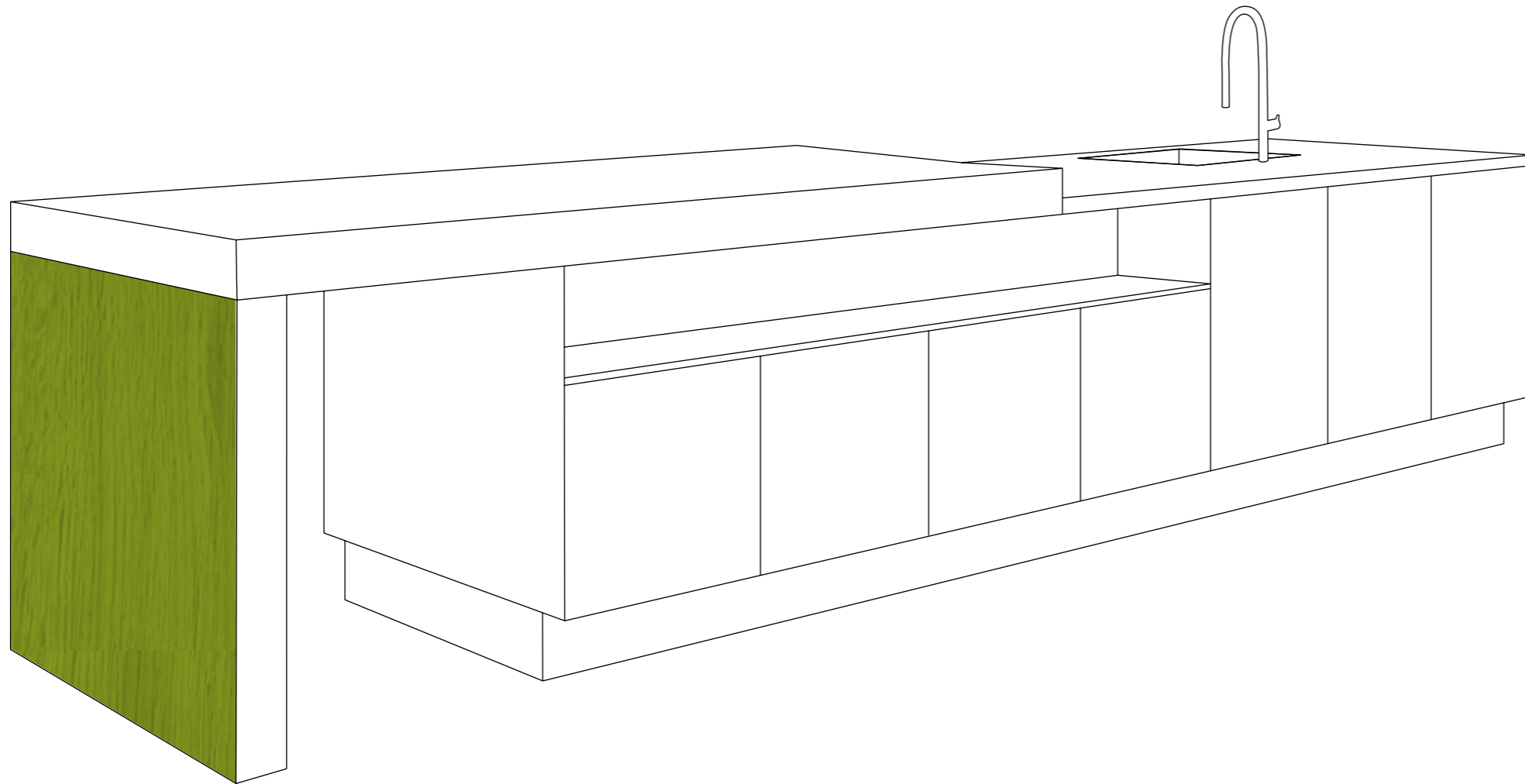



GB SUPPORT MATERIAL

Wood composite (e.g. chipboard, MDF) serve as support material. The used materials are suitable for interior fitting (including furniture) or as non-structural elements in dry area. In the area of fitted kitchen the wood composites are used for all refined panels for carcasses, fronts or surrounding material.

LAMINATE (KU/KG)

Surrounding materials in the surfaces KU and KG (shiny) are coated on both sides with a decorative laminate layer based on melamine resin. All four sides have laminated edges. All edges are applied by using PUR-hotmelt adhesive for highest water and temperature resistance.

WORKTOP FINISHES (AD) ON ONE SIDE

Recess panels in worktop decor are coated on one side with decorative laminate, consisting of thermosetting, resin-impregnated core papers and belong therefore to the most rigid surfaces available in furniture production.

HPL (ED)

Recess panels are coated on one side, 25 mm gable ends are coated on both sides with laminate, with the special feature of real metal for the top decor layer.

MATT LACQUER (LM)

The used support materials are covered with a varnishable coating and the edges are sealed and filled. The lacquer coating consists of a two-component lacquer. The good mechanical and chemical resistance and the great resistance to light and high stress are the characteristics of this lacquer. The lacquered surfaces are optimally protected against moisture through jointless lacquering.

EFFECT LACQUER (LA)

It is an embossed varnishable coating, which is lacquered with a smooth lacquer. The embossment creates a natural wood structure.

HIGH GLOSS LACQUER (LD) LAMINATE FORM EDGE SHINY

High gloss lacquered surrounding materials are coated on both sides with several lacquer layers to achieve an absolute smooth and even surface. The high mechanical and chemical resistance and the great resistance to light and high stress are the characteristics of this easy-to-care high gloss lacquer. Surrounding materials are edged allround with a shiny PVC edge. By using a special production process, the formed edge is fused with the surface. Thereby an almost jointless transition from edge to surface is achieved.

ES MATERIAL SOPORTE

Como materiales de base o soporte se utilizan materiales de madera (p. ej. tablero de virutas, MDF). Los materiales utilizados son apropiados para equipamientos interiores (incluyendo muebles) o como elementos no portantes en zonas secas. En la zona de la cocina empotrada se emplean materiales de madera para todos los tableros acabados que se utilizan para cuerpo/frente/entorno.

MATERIAL SINTÉTICO (KU/KG)

Los materiales de las superficies KU I y KG (brillantes) se hallan revestidos directamente por ambas caras con un recubrimiento plástico decorativo a base de resina de melamina. Presentan bordes gruesos por los 4 lados. Todos los bordes engrosados se colocan utilizando colas fusibles de PUR a prueba de agua y de calor.

IMITACIÓN DE ENCIMERA (AD) POR UN LADO

Los revestimientos de nichos, con la decoración de la encimera, se recubren por una de las caras con materiales laminados decorativos. El núcleo de dichos materiales decorativos está formado por papeles impregnados de resinas termoendurecibles y forman parte, por tanto, de las superficies más duras que se utilizan en la fabricación de muebles.

HPL (ED)

Los nichos se revisten por una cara, los laterales se revisten con material laminado por ambas caras. Con la particularidad de que la capa decorativa la constituye aquí un metal auténtico.

LACADO MATE (LM)

Los materiales soporte utilizados llevan un recubrimiento apto para barnizar, y los cantos se sellan y rellenan. Se pintan con un barniz de dos componentes. Estos barnizados se caracterizan por una buena resistencia mecánica y química, una extraordinaria resistencia frente a la acción de la luz y una gran capacidad para soportar esfuerzos o solitaciones. Gracias al barnizado sin ningún tipo de juntas, quedan las superficies óptimamente protegidas contra la humedad.

REPRO. LACADO (LA)

En este caso se trata de un recubrimiento estampado apto para ser barnizado. Para el barnizado se utiliza un barniz liso. Con el estampado se imita la estructura natural de la madera.

LACADO ALTO BRILLO (LD) CANTO DE POLÍMERO BRILLANTE

Sobre las dos caras de los materiales del entorno se aplican varias capas de barniz, con el fin de obtener una superficie absolutamente lisa y discreta. Estos barnizados de brillo intenso, de fácil mantenimiento, se caracterizan por una elevada resistencia mecánica y química, una extraordinaria resistencia frente a la acción de la luz y un gran cuerpo. Los materiales del entorno presentan un borde grueso y brillante de material plástico. El borde conformado se fusiona con la superficie gracias a un procedimiento especial de fabricación. De este modo se consigue una transición prácticamente sin junta de separación entre el borde y la superficie.

IT MATERIALE DI SUPPORTO

Come materiali di supporto vengono utilizzati derivati del legno (pannelli di truciolare, MDF). I materiali utilizzati sono adatti per applicazioni interne (compresi i mobili) o per elementi cartongesso che non supportano. Nell settore cucina vengono utilizzati derivati del legno per tutti i materiali corpo/ante/materiali dintorno.

LAMINATO (KU/KG)

Materiali circostanti nelle superfici KU e KG (lucido) sono con un rivestimento decorativo, in materiale plastico a base di resina melaminica, su entrambi i lati. I quattro lati sono rivestiti con un bordo in ABS. Tutti i bordi spessi con l'uso di colle termofusibili PUR vengono impiegati per una maggiore resistenza all'acqua e alla temperatura.

DECORO PIANI DI LAVORO (AD) SU UN LATO

I rivestimenti per nicchie nel decoro dei piani di lavoro vengono ricoperti su un lato con laminati decorativi. I laminati decorativi sono composti da carta decorativa termoindurente impregnata di resine melaminiche e fanno parte quindi delle superfici più dure disponibili nella realizzazione del mobile.

HPL (ED)

Schienale nicchia sono finiti su un lato, le spalle da 25mm su entrambi i lati. Con la caratteristica speciale che qui un vero metallo forma il decorativo superiore.

LACCATO OPACO (LM)

I materiali di supporto usati vengono ricoperti con un rivestimento laccabile e i bordi sono sigillati e frollati. La laccatura viene eseguita con una lacca a due componenti. Questa laccatura si contraddistingue per buone proprietà di resistenza meccanica e chimica, eccellente inalterabilità contro l'azione della luce, buon potere riempitivo, elevata capacità di resistenza alle sollecitazioni. Grazie alla laccatura senza giunture, le superfici laccate sono protette in modo ottimale contro l'umidità.

RIPRO. LACCATO (LA)

Si tratta di un rivestimento in rilievo verniciabile. La verniciatura avviene con una vernice liscia. Con il rilievo la struttura del legno naturale viene riprodotto.

LACCATO LUCIDO BRILLANTE (LD) BORDO ABS LUCIDO

I materiali degli elementi presenti nell'ambiente laccati lucidi brillanti sono ricoperti con più strati di lacca per ottenere una superficie liscia e riposante. Si tratta di un rivestimento in rilievo verniciabile. La verniciatura avviene con un rivestimento laccabile e i bordi sono sigillati e questa laccatura lucida brillante che richiede poca cura. I materiali degli elementi presenti nell'ambiente vengono dotati di un bordo spesso ABS lucido. Grazie ad uno speciale procedimento di produzione il bordo si fonde con la superficie. Si realizza in tal modo un passaggio dal bordo alla superficie quasi senza giuntura visibile.

FR LES MATÉRIAUX SUPPORTS

Les matériaux en bois sont utilisés comme matériaux supports (par ex. aggloméré, MDF). Les matériaux utilisés sont appropriés pour l'aménagement d'intérieur (y compris les meubles) ou pour les éléments non porteurs dans le domaine de la construction. Dans le domaine de la cuisine aménagée, les matériaux en bois sont utilisés pour tous les panneaux pour le corps/la façade/les matériaux décor.

MÉLAMINÉ (KU/KG)

Les matériaux décor dans les coloris KU et KG (brillant) sont recouverts des deux côtés par une feuille mélaminée décorée à base de résine de mélamine. Les chants sont recouverts des 4 côtés par un chant épais. Les chants épais sont collés grâce à une colle PUR très résistante à l'eau et aux températures.

COUL. DES PLANS DE TRAV. (AD) D'UN SEUL CÔTÉ

Les panneaux de crédence en coloris de plan de travail sont recouverts d'un seul côté d'un stratifié décoré. Ces stratifiés décorés sont fabriqués à partir de papier d'apprêt imprégné de résine thermodurcissable et font partie des matériaux les plus durs disponibles dans l'ameublement.

STRATIFIÉ (ED)

Les panneaux de crédence sont recouverts de stratifié d'un seul côté, et les joues de 25 mm de deux côtés. Avec la particularité que du vrai métal constitue la couche supérieure décorative.

LAQUÉ MAT (LM)

Les matériaux supports utilisés sont recouverts d'un papier d'apprêt préparé pour être peint et les chants sont scellés. Le laquage est réalisé avec une laqué à 2 composants. Ces laqués se caractérisent par une bonne résistance mécanique et chimique, une excellente constance contre les effets de la lumière, des couleurs puissantes, une résistance aux sollicitations élevées. Grâce à un laquage lisse, les surfaces laquées sont protégées de façon optimale contre l'humidité.

REPRO. LAQUÉ (LA)

Il s'agit ici d'un papier d'apprêt structuré préparé pour être peint. Le laquage se fait avec une laqué lisse. Grâce à la structure, on obtient une imitation naturelle du bois.

LUSTRE LAQUÉ (LD) CHANT ÉPAIS LÉGÈREM. ARRONDI BRILLANT

Les matériaux décor lustres laqués sont recouverts des 2 côtés de plusieurs couches de laqués, pour obtenir une surface absolument lisse. Ces laqués lustres, faciles d'entretien, se caractérisent par une bonne résistance mécanique et chimique, une excellente constance contre les effets de la lumière, des couleurs puissantes. Les matériaux décor reçoivent tout autour un chant épais légèrement arrondi brillant. Selon un procédé spécifique, les chants sont fusionnés avec la surface. Ainsi on obtient une transition presque sans jointure entre le chant et la façade.



GB Perfect edge – optimal gluing. Häcker kitchens consistently use the premium quality „water resist PUR gluing“ for all edges. A polyurethane reaction adhesive free from formaldehyde and solvents is used for this. The benefits include significantly stronger adhesion between the wooden material and the edge, as well as ideal protection against moisture penetration. For fronts, this technique means an outstanding look with invisible joints, combined with the best quality properties. But Häcker also goes one step further in the workmanship of the bodies. From now on, all transverse and back joints will also be given „water resist PUR gluing“. The consequences of this include a thicker edge for the bottom edges of hanging cupboards, in order to truly convert the entire range. This means that the company meets the highest expectations of its customers and justifies its own quality standard of creating premium quality kitchens „Made in Germany“.

ES Todos los bordes cuentan con el encolado impermeable «water-resist-PUResist», para el que se emplea un adhesivo reactivo de poliuretano exento de formaldehído y disolventes. Entre sus ventajas se incluye una adherencia considerablemente mayor entre los productos derivados de la madera y los bordes, así como una protección óptima contra la humedad. A los frentes, esta técnica les confiere un aspecto fabuloso gracias a la llamada junta de visibilidad cero combinada con características de calidad superior. En la elaboración de los armazones también vamos más allá: a partir de ahora, todos los bordes transversales y posteriores del armazón contarán con el encolado impermeable «water-resist-PUResist». Uno de los cambios realizados para ello, es equipar los bordes inferiores de los armarios altos con un borde más grueso para poder cambiar realmente todo el programa. Así, la empresa satisface las expectativas más exigentes de sus clientes y justifica su ambición por fabricar cocinas de calidad «Made in Germany».

IT Per tutti i bordi viene sempre impiegato un incollamento “resistente all’acqua PUResist” di alta qualità. Viene perciò utilizzato un adesivo reattivo in poliuretano senza formaldeide né solventi. Tra i vantaggi che ne derivano si contano un’adesione decisamente più forte tra materiale in legno e bordi e una protezione ottimale dalla penetrazione di umidità. Nei pannelli, questa tecnica consente un aspetto eccezionale con giunture a zero visibilità e migliori caratteristiche qualitative. Anche nella lavorazione del corpo abbiamo fatto un passo avanti: tutti i bordi trasversali e posteriori vengono dotati fin da subito di incollamento “resistente all’acqua PUResist”. Inoltre, i bordi inferiori dei pensili alti si presentano più spessi per consentire una conversione completa del programma. Così l’impresa soddisfa le più alte aspettative dei suoi clienti e giustifica le proprie esigenze di qualità nelle pregiate cucine “Made in Germany”.

FR Nous utilisons, pour toutes les arêtes, le « collage PUResist waterproof » de haute qualité. À cet effet, une colle polyuréthane sans formaldéhyde ni solvant est utilisée. Les avantages qu’elle présente sont notamment une adhérence sensiblement plus forte entre le bois et les arêtes ainsi qu’une protection optimale contre l’infiltration de l’humidité. Pour les façades, cette technique est synonyme d’un aspect visuel exceptionnel avec la fameuse « jointure invisible » allié à la meilleure qualité. Va également plus loin dans le traitement du corps : toutes les arêtes diagonales et arrières du corps reçoivent dès à présent un « encollage PUResist imperméable ». Les chants inférieurs des éléments muraux, entre autres, sont recouverts par une arête plus épaisse pour modifier vraiment entièrement le programme. L’entreprise répond ainsi aux plus grandes exigences de ses clients et justifie sa propre exigence de qualité sur des cuisines haut de gamme « Made in Germany ».

Sustainability

Sostenibilidad
Sostenibilità
Durabilité

GB Minimising the environmental impact, improving environmental protection.

ES Minimizar los impactos ambientales, mejorar la protección del medio ambiente.

IT Ridurre al minimo l'inquinamento ambientale, migliorare la tutela ambientale.

FR Réduire l'impact environnemental, améliorer la protection de l'environnement.



For love of nature
 Por amor al medio ambiente
 Per amore dell'ambiente
 Par amour de l'environnement



GB Minimise environmental pollution, improve environmental protection. As a family firm and industrial enterprise, we face up to our responsibility for the environment and for future generations. That's why we champion the protection of our natural resources. Our environmental management system has been certified since 2009. We pay particular attention to energy efficiency, sustainable waste disposal and emission reduction. The use of low-emission, water-based lacquer systems contributes significantly here. In order to achieve sustainability in all areas, we actively involve employees and suppliers in environmental protection. So that the future has a future.

ES Reducir el impacto medioambiental, mejorar la protección del medio ambiente. Como industria y empresa familiar, asumimos nuestra responsabilidad con el medio ambiente y con las futuras generaciones. Por ello, trabajamos para proteger nuestros recursos naturales básicos. Nuestro sistema de gestión medioambiental está certificado desde 2009. Prestamos especial atención a la eficiencia energética, la gestión sostenible de residuos y la reducción de emisiones. A ello contribuye considerablemente el empleo de sistemas de lacas al agua bajos en emisiones. Para alcanzar los objetivos en materia de sostenibilidad en todas las áreas, involucramos de forma activa en la protección medioambiental a empleados y proveedores. Por un futuro con perspectivas para todos.

IT Ridurre l'inquinamento ambientale e migliorarne la protezione. In qualità di impresa industriale e familiare, ci sentiamo responsabili per l'ambiente nei confronti delle generazioni future. Per questo ci impegniamo a garantire condizioni di vita naturali. Il nostro sistema di gestione ambientale è certificato dal 2009. Prestiamo particolare attenzione all'efficienza energetica, ad una gestione sostenibile dei rifiuti e alla riduzione delle emissioni. Un grande contributo è senz'altro rappresentato dai sistemi di idropittura a bassa emissione. Per raggiungere un livello di sostenibilità in tutti i settori, coinvolgiamo attivamente dipendenti e fornitori nella protezione ambientale. Affinché il futuro abbia un futuro!

FR Minimiser la pollution, améliorer la protection de l'environnement. En tant qu'industriel et entreprise familiale, nous prenons nos responsabilités envers l'environnement et les générations futures. C'est pour cela que nous nous investissons dans la protection des fondements naturels de la vie. Depuis 2009, notre management moderne de l'environnement est certifié. Nous veillons en particulier à l'efficacité énergétique, au traitement des déchets et à la diminution des émissions durables. L'utilisation de systèmes de laqués écophiles pauvres en émissions y contribue considérablement. Pour atteindre la viabilité dans tous les secteurs, nous associons activement les collaborateurs et les fournisseurs dans le sujet protection de l'environnement. Afin que l'avenir ait de l'avenir.

GB We reserve the right to alter sizes and specification of goods without notice and are not liable for printing errors. This catalogue supercedes previous catalogues.

ES Reservado el derecho de modificaciones en el programa, material, modelo y medidas. Todos los ejemplos de instalación se entienden sin compromiso. Nos reservamos el derecho de notificar las erratas de imprenta. El presente catálogo invalida a todos los demás publicados hasta ahora.

IT Con riserva di modifiche riguardanti programma, materiali, esecuzione, dimensioni. Gli esempi di arredamento mostrati non sono impegnativi. Con riserva di correzione di eventuali errori di stampa. La pubblicazione del presente catalogo annulla tutti i cataloghi precedenti.

FR Sous réserve de modifications de programmes, de matériaux et de dimensions. Exemples d'agencement non contractuels. Sous réserve d'erreurs éventuelles d'impression. La parution du présent catalogue annule et remplace tous les précédents.